

LOW VOLTAGE AC DRIVES

ABB general purpose drives

ACS580, 0.75 to 500 kW



—

Get it fast.

Use it easily.

Improve your processes.

**ACS580: general purpose drives
you can trust.**

Table of contents

04–05	The all-compatible ACS580 series
06–07	Easily take full control of your processes to comprehensively manage your plant
08–09	Typical industries and applications
10	Food and beverage domain expertise
10	Food and beverage software package for ACS580 (+N8057)
11	Cooling and refrigeration in food and beverage
12	Pumping in food and beverage
13	Ventilation in agriculture: Livestock and poultry
14–15	Complete offering, from wall-mounted drives to cabinet installations
16	Common features throughout the whole ACS580 product family
17	Standard ACS580 drives software with versatile features
18	Standard interface and extensions for plug-in connectivity
19	How to select a drive
20	ABB AC drives comply with the EU Ecodesign requirements
21	Technical data
22–23	Dimensions
24–26	Ratings, types and voltages
28	Easiness on a whole new level
29	Control panel options and mounting kits
30	Door mounting and daisy chaining
32–33	Higher enclosure class for cabinet-free installations even in harsh conditions
34–35	ACS580-07 cabinet-built drives
36–37	Commissioning, programming and customization tools
38–39	Communication and connectivity
40–41	Safety options
42–43	ABB Ability™ Condition Monitoring for drives
44–45	EMC – electromagnetic compatibility
46–47	Harmonic mitigation
48–49	For explosive atmospheres
50–51	Cooling and fuses
52	Circuit breakers
54–55	du/dt filters
56	Sine filters
57	ACS580 drives are compatible with the wide ABB product offering
58	Choose the right motor for your application
59	Synchronous reluctance motors
60–61	Selection guide
63	ABB Access
64	ABB Ability™ Mobile Connect for drives
65	ABB SmartGuide – ACS580
66–67	ABB Motion Services
68–69	ABB Drives Life Cycle Management
70–73	Ordering information

The all-compatible ACS580 series

Effortless process automation

The ACS580 is an all-compatible ABB general purpose drive, offered in a range of wall-mounted drives, drive modules and cabinet-built drives. It turns complicated to simple and controls processes productively and efficiently.

One product, many applications

ACS580 drives include all the essential components for typical light industry applications, with a scalable offering from 0.75 kW to 500 kW. The drive is ready to control compressors, conveyors, mixers, pumps and fans, as well as many other variable and constant torque applications. The all-compatible drives family ensures that you will always find the best drive for your needs. These drives share a similar user interface and PC tools, making using and learning them fast and easy.

The drive controls a wide range of applications in different industries, and yet it requires very little setting up or commissioning.

Reliability and consistent high quality

ACS580 drives are designed for customers who value high quality and robustness in their applications. The product features, such as coated boards and compact IP55 enclosure, make the ACS580 suitable for harsh conditions also. Additionally, all ACS580 drives are tested at maximum temperature and with nominal loads. The tests include performance and all protective functions.

Easier than ever before

ACS580 drives have all the essential features built-in reducing the commissioning and set-up time. The assistant control panel with multiple language choices is standard in ACS580 drives. Users can also upgrade to an optional Bluetooth control panel for wireless commissioning and monitoring. Primary settings and application control macros ensure quick product setup.

Instant availability

ACS580 products are available from central stocks around the world for immediate delivery up to 500 kW. The product is also widely available from ABB distributors globally.

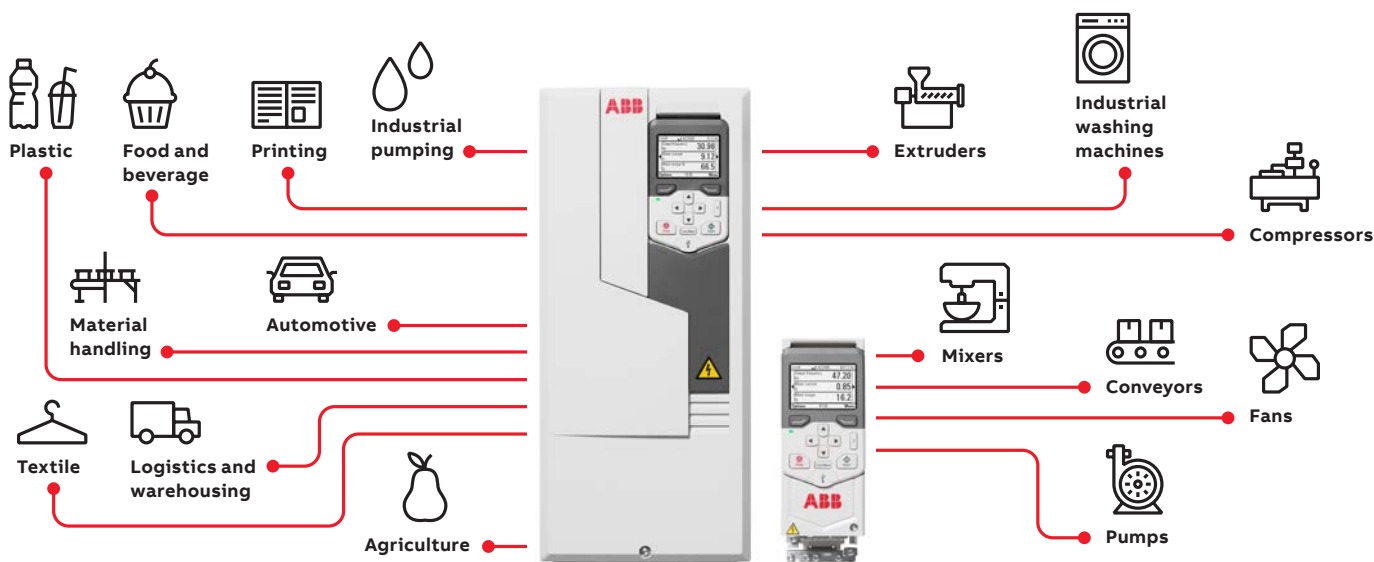



Easily take full control of your processes to comprehensively manage your plant

ACS580 drives are equipped with built-in features that simplify ordering and delivery, and reduce commissioning costs. Everything is provided in a single, compact and ready-to-use package for you to take full control of your processes.



Start-up and maintenance tool

Drive Composer PC tool for startup, configuration, monitoring and process tuning. The PC tool is connected to the drive's control panel via a USB interface.

Simple to select, install and use

Built-in features such as an EMC filter, choke, a Modbus RTU fieldbus interface and Safe Torque Off functionality simplify drive selection, installation and use.



Simplicity at your fingertips as standard

The control panel's straightforward primary settings menu with assistants help you set up the drive quickly and effectively.

Boosting energy efficiency

Energy efficiency information is available in the energy optimizer feature to help you optimize your processes. The energy optimizer feature operates both in scalar and vector control modes, ensuring maximum torque per ampere and reducing energy drawn from the supply. You can follow the saved energy, CO₂ emissions or money, and see how fast the drive brings you a return on investment.

Scalable performance

The ACS580 is a perfect match not only for energy-aware applications, but also for applications where sophisticated speed and torque control are needed.



Effortless automation and productivity for your success



Communication with all major automation networks

Optional fieldbus adapters enable connectivity with all major industrial automation networks.



Reliable, integrated safety

The ATEX-certified thermistor protection module, Ex II (2) GD, CPTC-02 provides enhanced process safety and easy, simplified installation.



Adaptive programming

Adaptive programming is ideal for creating simple programs for various applications to further optimize the process control. It does not require expertise in programming.

Designed for maximum reliability

Design features such as coated circuit boards, minimized airflow through the control board section, and earth fault protection make the ACS580 a safe choice for multiple applications.



Remote monitoring

A built-in web server and stand-alone datalogger NETA-21 module enable worldwide and secure access to drives.

Typical industries and applications

ACS580 drives improve process performance, increase productivity, reduce external components and ensure machine and personnel safety



01



02

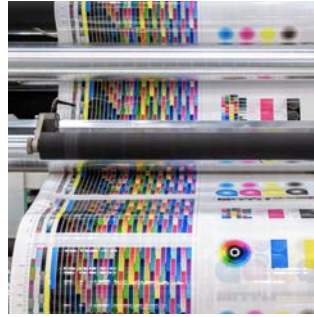

03

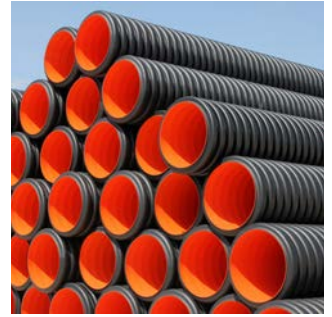

04



05



06



07



08











09

- 01 Food and beverage
- 02 Material handling
- 03 Printing

- 04 Rubber and plastics
- 05 Textile
- 06 Sawmill

- 07 Industrial pumping
- 08 Agriculture
- 09 Automotive

—
Streamline your processes
for profitable growth

Industry	Application	Customer benefits
Food and beverage 	Blowers, centrifuges, compressors, conveyors, fans, mills, pumps, separators, mixers, dryers, pelletizers	<ul style="list-style-type: none"> • Accurate control of the process increases the speed of food production while saving energy and improving work safety. Precise speed and torque control increases production uptime even when the load varies. • Increased starting torque with boost function allows the same drive series to be used in different applications in the manufacturing plant. • Safe Torque Off (SIL 3) function ensures machine and personnel safety. • The easy-to-use control panel with multiple languages and robust design reduce the time needed for maintenance. • The ATEX-certified thermistor protection module, Ex II (2) GD meets the safety requirements even in dusty environments.
Rubber and plastics 	Extruders, injection molding machines, pumps	<ul style="list-style-type: none"> • Smooth acceleration to prevent breaking the web of plastic film. • The scalable all-compatible platform allows easy process and component optimization with different drive types that share the same user interface and tools. • Wide range of supported fieldbus protocols for easy PLC integration.
Material handling 	Conveyors	<ul style="list-style-type: none"> • Accurate and precise speed and torque control increase production uptime even when the load varies. • Safe Torque Off (SIL 3) function ensures machine and personnel safety. • Minimized downtime with robust and reliable design. • DC or AC choke to mitigate harmonics. • External +24 V supply to keep the communication up when the mains supply is disconnected.
Printing 	Compressors, presses, winders	<ul style="list-style-type: none"> • Smooth acceleration to prevent breaking the paper. • The robust design of the drive reduces mechanical stress on process line equipment, lowering maintenance costs and capital expenditure. • Precise speed and torque control of applications increases process uptime by optimizing motor control.
Textile 	Bleaching machines, compressors, conveyors, industrial washing machines, extruders, fans, jet dyeing machines, pumps, stenter machines, stretchers, winders	<ul style="list-style-type: none"> • Precise speed or torque control for high stretching accuracy and better quality of the end product. • Adjustable torque limit to prevent damage to mechanical equipment. • Adjustable acceleration/deceleration ramps to improve pump control. • Real-time clock and timed functions for process optimization. • Increased productivity and faster payback times with multiple setups, allowing production of two different products. • Built-in counters for additional energy savings and preventive maintenance.
Sawmill 	Chippers, conveyors, feeders, dryers, pickers, drying kilns	<ul style="list-style-type: none"> • IP55/UL type 12 available up to 250 kW for harsh environments. • Cabinet-built drive IP54 up to 500 kW. • Safe Torque Off (SIL 3) function ensures machine and personnel safety. • External +24 V supply to keep the communications "alive" when the mains supply is turned off. • ATEX-certified thermistor protection module, Ex II (2) GD.
Industrial pumping 	Pump stations	<ul style="list-style-type: none"> • Additional energy savings with energy optimizer function. • Adjustable acceleration/deceleration ramps to improve pump control. • Minimized downtime with robust and reliable design. • ABB's extensive product and service offering for comprehensive process optimization.
Agriculture 	Fans, irrigators, pumps, sorters	<ul style="list-style-type: none"> • IP55/UL 12 available up to 250 kW harsh environments. • Wall-mounted power range up to 250 kW. • Drive modules and cabinet-built drives up to 500 kW.
Automotive 	Conveyors, fans, pumps	<ul style="list-style-type: none"> • ATEX-certified thermistor protection module, Ex II (2) GD. • Increased productivity and faster payback times with multiple setups. • Enhanced quality of end products with smooth control of the motor and process. • Safe Torque Off (SIL 3) function ensures machine and personnel safety. • Wide range of fieldbus networks supported, including PROFIBUS and PROFINET IO. • P55/UL Type 12 available up to 250 kW 400 V and high enclosure rating for harsh environments. • The robust design of the drive reduces mechanical stress on process line equipment, lowering maintenance costs and ensuring high production quality.

Food and beverage domain expertise

ABB has strong domain expertise in the food and beverage industry and its many subsegments. As part of ABB's general purpose drives family, the ACS580 is well suited to support a wide range of applications in the food and beverage subsegments below.

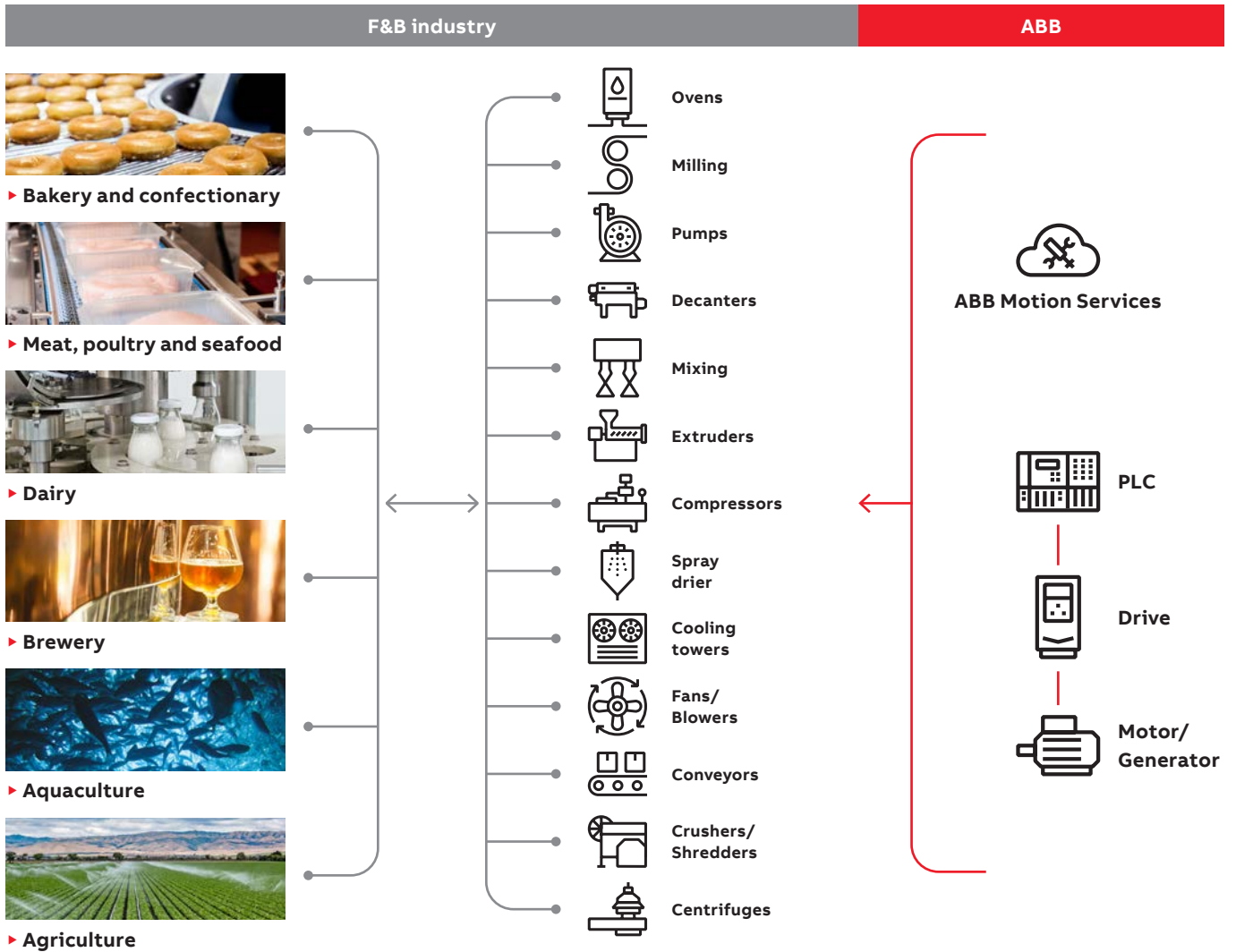

Food and beverage software package for ACS580 (+N8057)

To help our customers to be more effective, we offer a software package for the ACS580 which is dedicated to the food and beverage industry. The package consists of two different parts, which will improve your processes by utilizing segment-specific functions:

Food and beverage software package option for ACS580	
Plus code	Description
+N8057	Cooling compressor control ^{*)}
	Anti-cavitation ^{*)}

^{*)} More details on pages 11 and 12

Cooling and refrigeration in food and beverage

Food and beverage is the most significant segment for industrial refrigeration installations. From bakery to meat, dairy, fruit and vegetables, all require refrigeration across the entire cold chain which includes food process, cold storage, logistic centers and transportation.

Food and beverage software package for ACS580 (+N8057)

Cooling compressor control

Combining best-in-class drive technology with dedicated software for cooling compressors.

Cooling compressor macro

Sets typical parameter values for cooling compressor application and makes it easier to commission the drive.

Multi compressor control

Controlling more than one compressor with one drive, when needed, by changing all the relevant parameters and settings automatically.

Pressure to temperature conversion

Internal scaling is done based on refrigerant. System then automatically adjusts the cooling by using the PID.

Short cycle protection

Provides time delays in order to limit the number of starts to avoid damages from repetitive rapid-starting cycles.

Built-in intelligence



Reliable

Our high-quality package solution, based on our deep F&B domain expertise, includes reliable drives, motors and PLCs that help prevent unplanned downtime and other process risks.

Energy efficiency

Cooling systems are the biggest energy consumers in food processing plants. The use of VSDs in cooling compressors will provide average energy savings of 20-40% compared to running in DOL mode.

Easy to use

The user friendly interface and all compatible drive offering brings simplicity and time savings.

Flexible

By supporting all major Fieldbus protocols, wide I/O capacities and adaptive programming features, the ACS580 gives you freedom to design different kinds of control system topologies.

Pumping in food and beverage

A majority of the pump applications in food and beverage benefit from using a drive. The drive matches the pump-flow-rate with the actual demand, while saving energy and optimizing the production process.

The drive controls the pump-flow-rate by utilizing PID control and feedback from the sensor. This functionality controls the level, pressure, flow or temperature automatically.

Application example:

Level control of a beverage tank

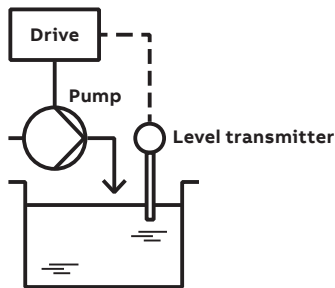

Food and beverage software package for ACS580 (+N8057)

Anti-cavitation

Cavitation is caused by local pressure changes in a liquid, creating vapor bubbles that can damage the pump and process when the vapor bubbles implode. In addition, cavitation can also cause unplanned downtime, production losses and even harm the end-product.

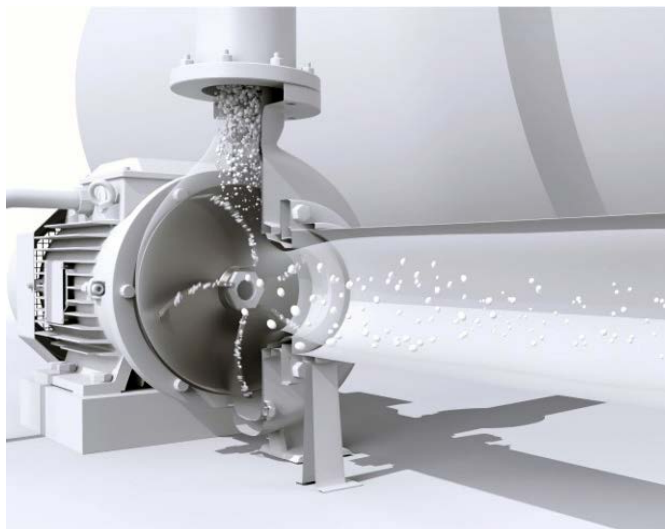

Quality in end-product

Anti-cavitation helps to avoid shock waves in the liquid. This may lead to poor product quality and lost revenues.

Lower total cost of ownership

Anti-cavitation eliminates the need for external sensors and reduces maintenance.

The Anti-cavitation feature enables reliable pump operations and increases productivity in the food and beverage industry.

Ventilation in agriculture: Livestock and poultry

ABB's agricultural expertise and the ACS580 deliver reliable ventilation conditions for your animals and increase overall productivity.

Robustness

- A conformal coating and IP55 option for harsh environment conditions
- Auto-derate option to avoid unwanted tripping of your applications like "oxygen supply fan"
- Built-in choke to reduce mains distortion

Animal welfare

- Optimal ventilation conditions ensure your animal's health and safety

Accessibility and flexibility

- Local/Remote control options
- Bluetooth panel option to connect your drive via your smart phone
- Long motor cable length

Cost savings

- Reducing fan speed via a drive, positively affects energy efficiency which lowers operating costs

Ammonia resistance for the complete drive (+C219)

Ammonia, which can be found in critical amounts in barns, has a corrosive effect on variable speed drives. The +C219 option enables ammonia resistance not only for the control board, but also for the entire drive. This robust design prevents unplanned downtimes while providing an extended lifetime. *)

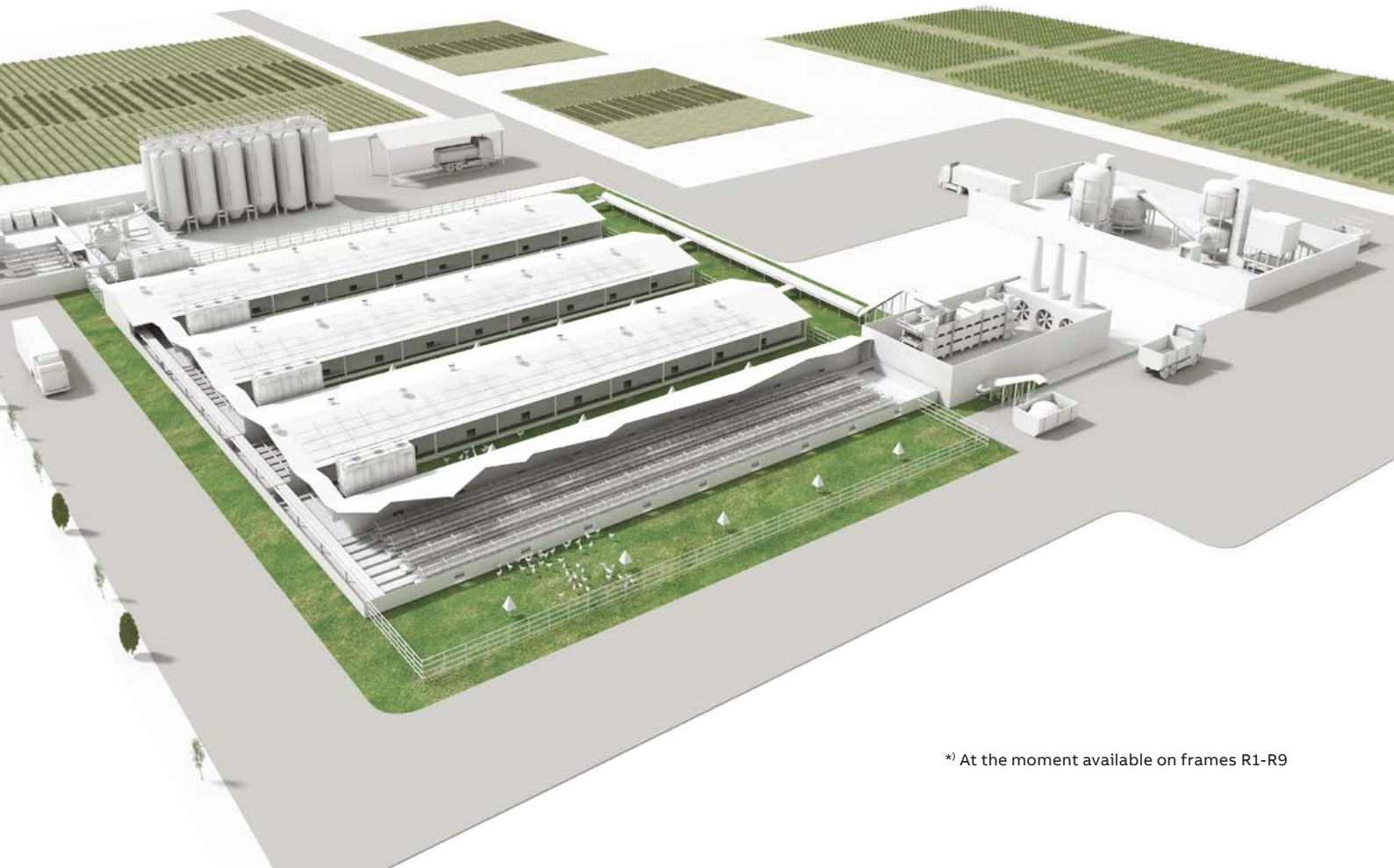

*) At the moment available on frames R1-R9

Complete offering, from wall-mounted drives to cabinet installations

Powerful, rugged and robust ACS580 drives ensure ease of use, scalability and quality. A wide power range and various mounting options and enclosure classes ensure you will find a drive for your installation and environment needs.

—
01 Wall-mounted
ACS580 IP21 drive

—
02 Wall-mounted
ACS580 IP55 drive

—
03 Flange-mounted
ACS580 IP21 drive

—
04 ACS580 drive
module with IP00

—
05 Cabinet-built
ACS580 drive
with IP42

Wall-mounted IP21 drives, standard

Wall-mounted IP21 drives are available in a power and voltage range from 0.75 to 250 kW and 3-phase 380-480 V. Side-by-side mounting, flange mounting and horizontal mounting are all available for wall-mounted ACS580 drives.



—
01

Wall-mounted IP55 drives, +B056

The IP55 drive is designed for applications exposed to dust, moisture, vibrations and other harsh environments. It is similar in size to the compact IP21 drives, which provides significant savings in space, maintenance, engineering, and material costs, as well as in setup and commissioning time.



—
02

IP20 drives without a conduit box for cabinet installations, +P944

The option code +P944 removes the conduit box from the frames R5-R9, making it easier to install the drive in compact cabinets with limited space. These IP20 units enable you to optimize the solution from cost and dimensioning point of view, and reduce waste. This option is also compatible with the flange mounting option for the frames R5-R9.

Flange mounting option, +C135

The flange mounting option enables smaller cabinets to be used as the backside of the drive is installed outside of the cabinet. This mounting method improves the cooling system and decreases the investment in the cabinets. The flange mounting option is compatible only with the standard IP21 units. It maintains the protection class of IP55 on the backside of the drive, while the front side of the drive is IP20. The option is also available as a loose item with an MRP code. If necessary, the conduit box can be removed from the frames R5-R9 with an option code +P944.



Flange mounting kit MRP codes	Frame size
3AXD50000105311	R1 (IP21)
3AXD50000105328	R2 (IP21)
3AXD50000105335	R3 (IP21)
3AXD50000031460	R4 (IP21)
3AXD50000031461	R5 (IP21)
3AXD50000018852	R6 (IP21)
3AXD50000018853	R7 (IP21)
3AXD50000018854	R8 (IP21)
3AXD50000018855	R9 (IP21)

Drive modules for cabinet installations, IP00 and IP20 (+B051)

ACS580 drive modules are optimal for system integrators, cabinet builders or OEMs who want to optimize the cabinet design in the 250-500 kW range but do not want to compromise on easy installation, commissioning and maintenance. 3-phase 380-480 V.



Construction options for ACS580-04	
Plus code	Description
+H370	Full-size cable connection terminals for input power cables
+OH371	Drive module without full-size output cable connection terminals
+OH534	No pedestal
+OP919	No cabinet installation ramp
+P906	Remote control board

Cabinet-built drives, IP21, IP42 (+B054) and IP54 (+B055)

Cabinet-built drives are available with IP21 protection class as standard and IP42 and IP54 as options in frame sizes R6 to R11. The drives have a unique cooling arrangement even for harsh environments and a global cabinet design with a high quality standard. The power range is from 75 kW to 500 kW, and the voltage range is 3-phase 380-480 V.



Common features throughout the whole ACS580 product family



Standard ACS580 features

Choke and EMC

- DC or AC choke mitigates harmonics
- Fulfills standard the EN61000-3-12 standard
- EMC C2 filter for R1-R9 allows safe installation in first environment
- EMC C3 and common mode filter for R10 and R11 allow safe installation in second environment
- Optional EMC C1 filter for R1-R5 ensures the best electro-magnetic performance for first environment. Available for option +E223 and +F316.

Scalar and vector control for process control

- Scalar control for effortless process control
- Vector control for accurate speed and torque control in demanding applications
- Support for induction, permanent magnet and synchronous reluctance motors (SynRM)

Extensive I/O connections

- The ACS580 features extensive I/O connections for flexible configuration in various applications
- Colored and bigger terminals for easy commissioning and diagnostics

Assistant control panel and primary settings

- The ACS-AP-S assistant control panel speaks your language
- USB interface for PC and tool connection
- Help button for problem-solving and immediate diagnostics

Integrated Safe Torque Off (STO)

- Safe Torque Off for implementing safe machinery
- SIL 3, PL e

Brake chopper

- The brake chopper is built-in as standard for ACS580 frames up to R3. Braking control is integrated into ACS580 drives.
- Optional external brake chopper can be added for the frames R4-R9.

Performance

The ACS580 is suitable for various types of applications, including constant torque, linear and variable torque applications.



Shared features of the ABB all-compatible drives portfolio

Same user interface

The drives follow the same operation logic and yet, there is an optimal drive from the smallest water pump to the biggest cement kiln, and everything in the between. When you have learned to use one drive, it is easy to use other drives in the portfolio.

Same PC tools

Free Drive Composer entry available at www.abb.com.

Simple connectivity

- The ACS580 supports F-series fieldbus adapters used in the ABB all-compatible platform
- Mobile phone connectivity via the optional Bluetooth assistant control panel
- Fieldbus settings are made easy with the redesigned simple settings menu

The same parameter structure makes the all-compatible platform easy to use.

Standard ACS580 drives software with versatile features

Save commissioning and learning time with the assistant control panel's clear and intuitive user interface and different assistants.

Improve the performance of the motor and process with sophisticated process control in scalar and vector control modes. The drive supports a wide range of motors, including induction and permanent magnet motors.

Analyze and optimize the application with the load profile log, which shows how the drive is operating.

Reduce motor noise with spreading the switching frequencies over a user-specified range.

Reduce costs with the built-in and standalone process PID. It makes the ACS580 a self-governing unit requiring only an external process measurement. No external logic input from the control room is needed.

Scale up and customize the drive to your application's requirements with flexible parameter pointers or adaptive programming.

Optimize energy efficiency with features that help you to save and manage energy. You can monitor the hourly, daily and cumulative energy consumption via kWh counters.

Analyze and resolve issues with the control panel's diagnostics menu. You can quickly analyze why the drive is performing as it is, whether running, stopped or running at the present speed.

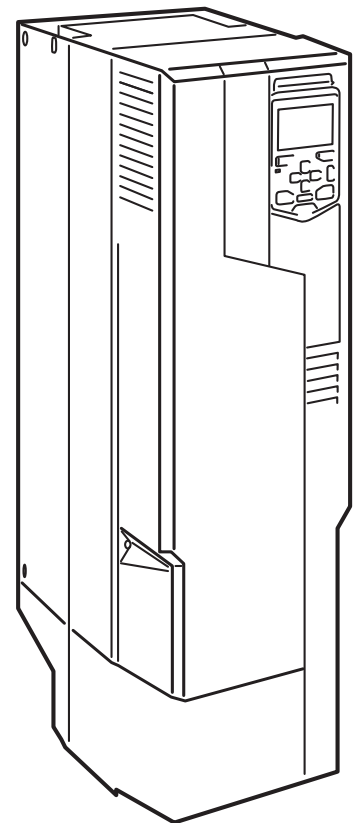

Standard interface and extensions for plug-in connectivity

ACS580 drives offer a wide range of standard interfaces. In addition, the drive has two option slots that can be used for extensions, including fieldbus adapters and input/output extension modules that allow an external +24 V supply with frame sizes R1 to R5. For frames R6-R11 external +24 V terminals are already integrated on the control board. For further information, please see the ACS580 user manual.

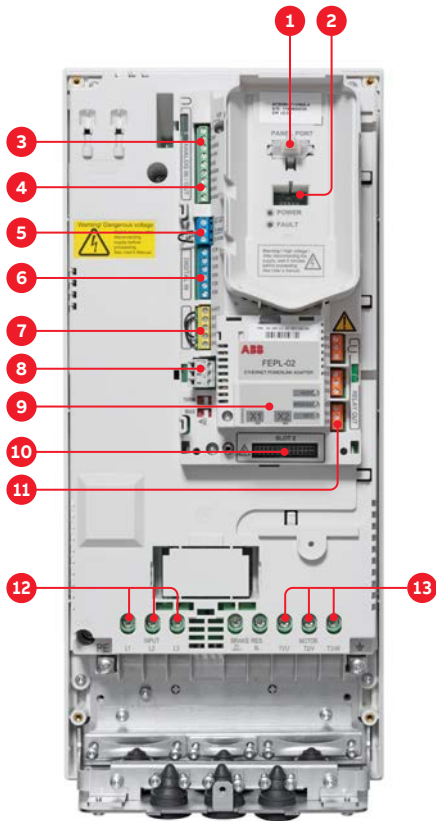

1. Panel port (PC tools, control panel)
2. ABB drive customizer port for programming the drive without mains
3. Analog inputs (2 × AI)
4. Analog outputs (2 × AO)
5. 24 V AC/DC output
6. Digital inputs (6 × DI)
7. Safe Torque Off (STO)
8. Embedded fieldbus
9. Communication options (fieldbuses)
10. I/O extensions
11. Relay outputs (3 × RO)
12. Mains connection
13. Motor connection

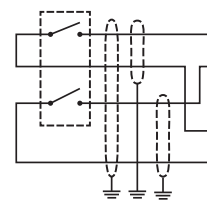
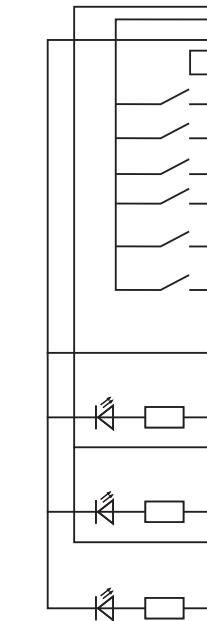
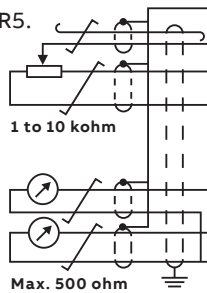

Default factory I/O connection diagram: Macro ABB standard

Terminal	Meaning	Default macro connections
X1 Reference voltage and analog inputs and outputs		
1	SCR	Signal cable shield (screen)
2	AI1	External frequency reference 1: 0 to 10 V
3	AGND	Analog input circuit common
4	+10 V	Output reference voltage 10 V DC
5	AI2	Not used
6	AGND	Analog input circuit common
7	AO1	Output frequency: 0 to 20 mA
8	AO2	Output current: 0 to 20 mA
9	AGND	Analog output circuit common
X2 & X3 Aux. voltage output and programmable digital inputs		
10	+24 V	Auxiliary voltage output +24 V DC
11	DGND	Auxiliary voltage output common
12	DCOM	Digital input common for all DI
13	DI1	Start/Stop: Activate to start
14	DI2	Fwd/Rev: Activate to reverse rotation direction
15	DI3	Constant speed selection
16	DI4	Constant speed selection
17	DI5	Ramp pair selection: Activate to select second pair
18	DI6	Not used
X6, X7, X8 Relay outputs		
19	RO1C	Ready
20	RO1A	250 V AC/30 V DC 2 A
21	RO1B	
22	RO2C	Running
23	RO2A	250 V AC/30 V DC 2 A
24	RO2B	
25	RO3C	Fault (-1)
26	RO3A	250 V AC/30 V DC 2 A
27	RO3B	
X5 EIA-485 Modbus RTU		
29	B+	Built-in Modbus RTU fieldbus interface
30	A-	
31	DGND	
X4 Safe Torque Off		
34	OUT1	Safe Torque Off. Both circuits must be closed for the drive to start. The circuits are closed with jumper wires in the standard delivery.
35	OUT2	
36	SGND	
37	IN1	
38	IN2	
X10*) 24 V AC/DC		
40	24 V	AC/DC-in. Ext. 24 V AC/DC input to power up the control unit when the main supply is disconnected
41	24 V	AC/DC+in.

*) The terminals 40-41 are integrated only in the frame sizes R6-R11. For the frame sizes R1-R5 I/O options (+L) are needed.

How to select a drive

The right drive is extremely easy to select. The following instructions show you how to order the right drive for your application.

Start by identifying your supply voltage.

Based on the supply voltage, follow either the right side or the middle section of the rating table. See pages 24, 25 and 26.

Select your drive's order code from the rating table based on your motor's nominal power rating.



Choose the motor power and current rating from the rating table on pages 24, 25 and 26.

Pages 24, 26 and 26

Pages 24, 25 and 26

Choose your options (on pages 30, 32, 38 and 49) and add the option codes to the drive's order code. Remember to use a "+" mark before each option code or order them as loose items. For more information, see pages 64, 65, 66 and 67.

Pages 30, 32, 38 and 49



ABB AC drives comply with the EU Ecodesign requirements

The Ecodesign regulation (EU) 2019/1781 is the legislative framework, that sets minimum energy efficiency requirements for low voltage induction motors and variable speed drives. AC drives and power drive systems are classified according to their power losses. From July 2021, the minimum requirement for non-regenerative AC drives in EU is IE2.

ABB’s AC drives (micro and machinery, general purpose, industrial and industry-specific drives) comply with the strictest requirements of the standard for energy efficiency and are classified as IE2.

Energy efficiency classes for a Complete Drive Module (CDM)

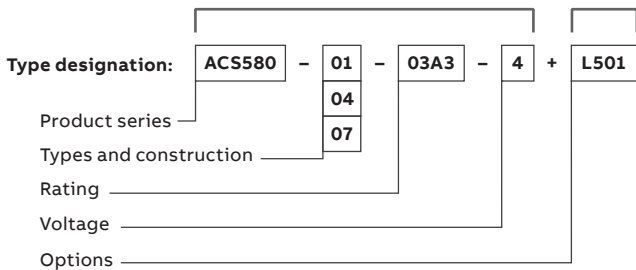
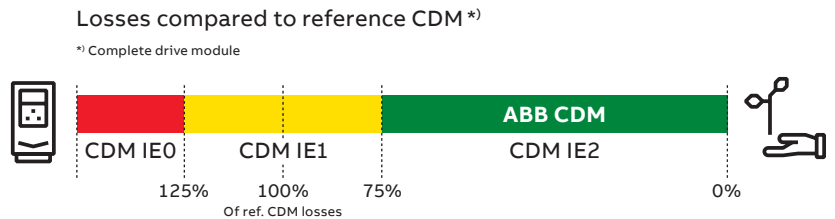

Markings on the ABB LV AC drives

Unique identifier QR code to Ecodesign information



IE class and % loss of rated apparent power 50 Hz, 400 V

IE2 (90;100) 2,3 %

Unique QR codes are located on the rating plate and/or the front side of the drive.

ABB EcoDesign web-based tool



- Calculates absolute and relative losses and efficiency data at standard and user-defined operating points according to EU regulation 2019/1781 for complete drive module (CDM), LV motors with VSD supply, and power drive system (PDS)
- Losses and efficiency data at operating points in graphical and table format
- Printable efficiency report with possibility to customize title and additional details
- Report can be converted to PDF or CSV format and shared via email

The regulation was implemented in two steps:

- Step 1: July 1, 2021**
- Power range: from 0.12 to 1000 kW
 - 3-phase LV AC drives with diode rectifier
 - Drive manufacturers must declare power losses in percentage of the rated apparent output power at 8 different operating points as well as standby losses. The international IE level is given at the nominal point. Drives fulfilling the requirements will be CE marked.

Out of scope of the regulation:

- All drives without CE marking
- Following low voltage AC drives: regenerative drives, low-harmonic drives (THD < 10%), multiple AC-output drives and single-phase drives.
- Medium voltage drives, DC drives and traction drives
- Drive cabinets with already conformity assessed modules

Step 2: July 1, 2023
No changes for AC drives

Technical data

Mains connection	
Input voltage and output power range	3-phase, U_N 200 to 240 V, +10%/-15% ACS580-01: from 0.75 up to 75 kW 3-phase, U_N 380 to 480 V, +10%/-15% ACS580-01: from 0.75 up to 250 kW ACS580-04: from 250 up to 500 kW ACS580-07: from 75 up to 500 kW Auto-identification of supply voltage
Frequency	from 47 to 63 Hz
Power factor	$\cos\varphi = 0.98$
Efficiency (at nominal power)	98%
Efficiency class (IEC 61800-9-2)	IE2
Motor connection	
Voltage	0 to U_N , 3-phase
Frequency	0 to 500 Hz
Motor control	Scalar and vector control
Torque control	Torque step rise time: <10 ms with nominal torque Non-linearity: $\pm 5\%$ with nominal torque
Speed control	Static accuracy: 20% of motor nominal slip Dynamic accuracy: 1% seconds with 100% torque step
Maximum recommended motor cable length	R1: 100 m R2: 200 m R3-R11: 300 m
Supported motor types	Asynchronous AC induction motors (IM) Permanent magnet motors (PMSM/IPM, PMSM/SPM) Synchronous reluctance motors (SynRM) Permanent magnet assisted synchronous reluctance motors (PMaSynRM, SynRM2, EC Titanium)
Product compliance	
CE Low Voltage Directive 2014/34/EU, EN 61800-5-1: 2007 Machinery Directive 2006/42/EC, EN 61800-5-2: 2007 EMC Directive 2014/30/EU, EN 61800-3: 2004 + A1: 2012 RoHS directive 2011/65/EU Quality assurance system ISO 9001 and Environmental system ISO 14001 Waste electrical and electronic equipment directive (WEEE) 2002/96/EC RoHS directive 2011/65/EU UL, EAC, RCM, UL, cUL TÜV Nord (safety functions) UKCA Ecodesign (EU) 2019/1781	
Harmonics compliance	
Built-in optimized DC choke as standard in AC580-01 meets the requirements of IEC 61000-3-12:2011.	
EMC according to EN 61800-3:2004 + A1:2012	
Frames R1 to R9 with built-in C2 category filter as standard Frames R10 and R11 with preconfigured built-in C3 category filter option	
Inputs and outputs (standard configuration)	
2 analog inputs	Selection of Current/Voltage input mode is user programmable.
Voltage signal	0 (2) to 10 V, R in >200 k Ω
Current signal	0 (4) to 20 mA, R in = 100 Ω
Potentiometer reference value	10 V $\pm 1\%$ max. 20 mA
2 analog outputs	AO1 is user programmable for current or voltage. AO2 current
Voltage signal	0 to 10 V, R load: >100 k Ω
Current signal	0 to 20 mA, R load: <500 Ω
Internal auxiliary voltage	24 V DC $\pm 10\%$, max. 250 mA
6 digital inputs	12 to 24 V DC, 24 V AC, Connectivity of PTC sensors supported by a single digital input. PNP or NPN connection (5 DI's with NPN connection).

3 relay outputs	Maximum switching voltage 250 V AC/30 V DC Maximum continuous current 2 A rms
Supported thermistors	Any of the analog inputs, or digital input 6, are configurable for PTC with up to 6 sensors. Both analog outputs can be used to feed the PT100, PT1000, KTY83, KTY84 or Ni1000 sensors. For more detailed information please see the ACS580 hardware manual.
Environmental limits	
Ambient temperature	
Transport	-40 to +70 °C
Storage	-40 to +70 °C
Operation area	ACS580-01: -15 to +50 °C. No frost allowed R1 to R9 from +40 to +50 °C with derating ACS580-04: -15 to +55 °C. No frost allowed R10 to R11 from +40 to +55 °C with derating ACS580-07: 0 to +40 °C. No frost allowed R6 to R11 from +40 to +50 °C with derating
Cooling method	Dry clean air
Air-cooled	
Altitude	0 to 1,000 m Without derating 1,000 to 4,000 m With derating of 1%/100 m For more detailed information please see the ACS580 hardware manual
Relative humidity	5 to 95%, no condensation allowed
Degree of protection	ACS580-01: IP21 as standard. IP55 as option (frames R1 to R9) ACS580-04: IP00 as standard. IP20 as option (frames R10 to R11) ACS580-07: Cabinet-built frames R6 to R11: IP21 as standard. IP42 and IP54 as options
Functional safety	Safe Torque Off (STO according EN 61800-5-2) IEC 61508 ed2: SIL 3. IEC 61511: SIL 3. IEC 62061: SIL CL 3. EN ISO 13849-1: PL e
Contamination levels	No conductive dust allowed
Storage	IEC 60721-3-1. Class 1C2 (chemical gases). Class 1S2 (solid particles) [*]
Operation	IEC 60721-3-3. Class 3C2 (chemical gases). Class 3S2 (solid particles) [*]
Transportation	IEC 60721-3-2. Class 2C2 (chemical gases) Class 2S2 (solid particles) [*]
External power supply	
Standard: ACS580-01 frames R6-R9, ACS580-04 all frames and ACS580-07 all frames 1.5 A at 24 V AC/DC $\pm 10\%$	
With option: ACS580-01 frames R1-R5 1.04 A at 24 V AC/DC $\pm 10\%$	
Communication	
Protocol as standard (EIA-485): Modbus RTU. Protocols available as option: EtherNet/IP, EtherNet POWERLINK, Modbus/TCP, EtherCAT, PROFINET IO, PROFISafe (for STO and SS1-t functions), CANopen, ControlNet, DeviceNet and Profibus DP.	
Protection functions	
Overvoltage controller Undervoltage controller Motor and motor cable earth-leakage monitoring Motor and motor cable short-circuit protection Motor overtemperature protection Output and input switch supervision Motor overload protection Phase-loss detection (both motor and supply) Under load supervision (belt loss detection) Overload supervision Stall protection Loss of control reference	
[*] C = Chemically active substances S = Mechanically active substances	

Dimensions

ACS580-01 IP21, standard

Frames	Height 1		Height 2		Width		Depth		Weight	
	(mm)	(in)	(mm)	(in)	(mm)	(in)	(mm)	(in)	(kg)	(lb)
R1	373	14.7	331	13.0	125	4.9	223	8.8	4.6	10.1
R2	473	18.6	432	17.0	125	4.9	229	9.0	6.6	14.6
R3	490	19.3	490	19.3	203	8.0	229	9.0	11.8	26.0
R4	636	25.0	636	25.0	203	8.0	257	10.2	19	41.9
R5	732	28.8	596 ^{*)}	23.5	203	8.0	295	11.6	28.3	62.4
R6	727	28.6	548 ^{*)}	21.6	252	9.9	369	14.5	42.4	93.5
R7	880	34.6	600 ^{*)}	23.7	284	11.2	370	14.6	54	119.1
R8	965	38.0	680 ^{*)}	26.7	300	11.8	393	15.5	69	152.2
R9	955	37.6	680 ^{*)}	26.8	380	15.0	418	16.5	97	213.9

Height 1: Total height of the drive with glandbox
 Height 2: Total height of the drive without glandbox
^{*)} Height with the option +P944



ACS580-01 IP55, +B056

Frames	Height 1		Height 2		Width		Depth		Weight	
	(mm)	(in)	(mm)	(in)	(mm)	(in)	(mm)	(in)	(kg)	(lb)
R1	403	15.9	403	15.9	128	5.0	233	9.2	4.8/5.4	10.6/11.2
R2	503	19.8	503	19.8	128	5.0	239	9.4	6.8/7.4	15.0/16.3
R3	490	19.3	733	28.9	206	8.1	237	9.3	13/15	28.7/33.1
R4	636	23.6	879	34.6	203	8.0	265	10.2	20/23.3	44.1/51.4
R5	732	28.8	1023	40.3	203	8.0	320	12.6	29/33	64.0/72.8
R6	727	28.6	-	-	252	9.9	380	15.0	43	94.8
R7	880	34.6	-	-	284	11.2	381	15.0	56	123.5
R8	965	38.0	-	-	300	11.8	452	17.8	77	169.8
R9	955	37.6	-	-	380	15.0	477	18.78	103	227.1

Height 1: Total height of the drive
 Height 3: Total height of the drive with options +F287, +F316, +E223
 Note: Options +F287, +F316, +E223 are available only for the IP55 frames R1-R5



ACS580-01 flange mounting dimensions, with +C135 or a loose option kit for IP21

Frames	Height		Width		Offs. Out		Offs. In		Weight	
	(mm)	(in)	(mm)	(in)	(mm)	(in)	(mm)	(in)	(kg)	(lb)
R1	461	18.2	206	8.1	133	5.2	109	4.3	4.6	10.1
R2	551	21.7	206	8.1	130	5.1	114	4.5	6.5	14.6
R3	613	24.1	290	11.4	118	4.6	116	4.6	11.8	26.0
R4	776	30.6	290	11.4	120	4.7	137	5.4	19	41.9
R5	776	30.6	290	11.4	124	4.9	173	6.8	28.3	62.4
R6	672	26.5	374	14.7	193	7.6	167	6.6	42.4	93.5
R7	722	28.4	406	16.0	194	7.6	169	6.7	54	119.1
R8	814	32.1	433	17.0	202	8.0	184	7.2	69	152.2
R9	804	31.7	502	19.8	204	8.0	209	8.2	97	213.9

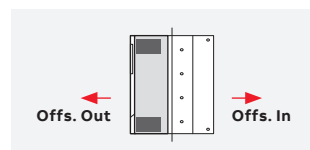

ACS580-04 IP00, standard

Frames	Height		Width		Depth		Weight	
	(mm)	(in)	(mm)	(in)	(mm)	(in)	(kg)	(lb)
R10	1462	57.6	350	13.8	529	20.8	162	357.2
R11	1662	63.4	350	13.8	529	20.8	200	440.9

ACS580-04 IP20, +B051

Frames	Height		Width		Depth		Weight	
	(mm)	(in)	(mm)	(in)	(mm)	(in)	(kg)	(lb)
R10	1462	57.6	350	13.8	529	20.8	162	357.2
R11	1662	63.4	350	13.8	529	20.8	200	440.9



ACS580-07 IP21, standard

Frames	Height		Width		Depth		Weight	
	(mm)	(in)	(mm)	(in)	(mm)	(in)	(kg)	(lb)
R6	2145	84.4	430	16.9	673	26.5	210	463
R7	2145	84.4	430	16.9	673	26.5	220	485
R8	2145	84.4	530	20.9	673	26.5	255	562
R9	2145	84.4	530	20.9	673	26.5	275	606
R10	2145	84.4	830	32.7	698	27.5	410	904
R11	2145	84.4	830	32.7	698	27.5	440	970



ACS580-07 IP42, +B054

Frames	Height		Width		Depth		Weight	
	(mm)	(in)	(mm)	(in)	(mm)	(in)	(kg)	(lb)
R6	2145	84.4	430	16.9	673	26.5	210	463
R7	2145	84.4	430	16.9	673	26.5	220	485
R8	2145	84.4	530	20.9	673	26.5	255	562
R9	2145	84.4	530	20.9	673	26.5	275	606
R10	2145	84.4	830	32.7	698	27.5	410	904
R11	2145	84.4	830	32.7	698	27.5	440	970



ACS580-07 IP54, +B055

Frames	Height		Width		Depth		Weight	
	(mm)	(in)	(mm)	(in)	(mm)	(in)	(kg)	(lb)
R6	2145	84.4	430	16.9	673	26.5	210	463
R7	2145	84.4	430	16.9	673	26.5	220	485
R8	2145	84.4	530	20.9	673	26.5	255	562
R9	2145	84.4	530	20.9	673	26.5	275	606
R10	2315	91.14	830	32.7	698	27.5	410	904
R11	2315	91.14	830	32.7	698	27.5	440	970

Ratings, types and voltages

Wall-mounted drives, ACS580-01 (3-phase supply voltage range 380-480 V)													
Frame type	Frame size	3-phase, $U_N = 400\text{ V}$							3-phase, $U_N = 480\text{ V}$				
		Nominal ratings		Light-duty use		Heavy-duty use		Max. output current	Light-duty use		Heavy-duty use		Max. output current
		P_N (kW)	I_N (A)	I_{Ld} (A)	P_{Ld} (kW)	I_{Hd} (A)	P_{Hd} (kW)	I_{max} (A)	I_{Ld} (A)	P_{Ld} (hp)	I_{Hd} (A)	P_{Hd} (hp)	I_{max} (A)
ACS580-01-02A7-4	R1	0.75	2.6	2.5	0.75	1.8	0.55	3.2	2.1	1	1.6	0.75	2.9
ACS580-01-03A4-4	R1	1.1	3.3	3.1	1.1	2.6	0.75	4.7	3	1.5	2.1	1	3.8
ACS580-01-04A1-4	R1	1.5	4	3.8	1.5	3.3	1.1	5.9	3.5	2	3	1.5	5.4
ACS580-01-05A7-4	R1	2.2	5.6	5.3	2.2	4	1.5	7.2	4.8	3	3.4	2	6.1
ACS580-01-07A3-4	R1	3	7.2	6.8	3	5.6	2.2	10.1	6	3	4	3	7.2
ACS580-01-09A5-4	R1	4	9.4	8.9	4	7.2	3	13	7.6	5	4.8	3	8.6
ACS580-01-12A7-4	R1	5.5	12.6	12	5.5	9.4	4	15.3	12	7.5	7.6	5	11.4
ACS580-01-018A-4	R2	7.5	17	16.2	7.5	12.6	5.5	22.7	14	10	11	7.5	19.8
ACS580-01-026A-4	R2	11	25	23.8	11	17	7.5	30.6	23	15	14	10	25.2
ACS580-01-033A-4	R3	15	32	30.4	15	24.6	11	44.3	27	20	21	15	37.8
ACS580-01-039A-4	R3	18.5	38	36.1	18.5	31.6	15	56.9	34	25	27	20	48.6
ACS580-01-046A-4	R3	22	45	42.8	22	37.7	18.5	67.9	44	30	34	25	61.2
ACS580-01-062A-4	R4	30	62	58	30	44.6	22	81	52	40	40	30	76
ACS580-01-073A-4	R4	37	73	68.4	37	61	30	109.8	65	50	52	40	104
ACS580-01-089A-4	R4	45	89	83	45	72	37	129.6	77	60	65	50	117
ACS580-01-088A-4	R5	45	88	82.7	45	72	37	129.6	77	60	65	50	122
ACS580-01-106A-4	R5	55	106	100	55	87	45	156.6	96	75	77	60	148
ACS580-01-145A-4	R6	75	145	138	75	105	55	178	124	100	96	75	178
ACS580-01-169A-4	R7	90	169	161	90	145	75	247	156	125	124	100	247
ACS580-01-206A-4	R7	110	206	196	110	169	90	287	180	150	156	125	287
ACS580-01-246A-4	R8	132	246	234	132	206	110	350	240	200	180	150	350
ACS580-01-293A-4	R8	160	293	278	160	246 ^{*)}	132	418	260	200	240	150	418
ACS580-01-363A-4	R9	200	363	345	200	293	160	498	361	300	302	250	542
ACS580-01-430A-4	R9	250	430	400	200	363 ^{**))}	200	545	414	350	361	300	542

Nominal ratings, ACS580-01

I_N	Rated current available continuously without overloadability at 40 °C.
P_N	Typical motor power in no-overload use.

Maximum output current

I_{max}	Maximum output current. Available for 2 seconds at start.
-----------	---

Light-overload use

I_{Ld}	Continuous current allowing 110% I_{Ld} for 1 minute every 10 minutes at 40 °C.
P_{Ld}	Typical motor power in light-duty use.

Heavy-duty use

I_{Hd}	Continuous current allowing 150% I_{Hd} for 1 minute every 10 minutes at 40 °C. ^{*)} Continuous current allowing 130% I_{Hd} for 1 minute every 10 minutes at 40 °C. ^{**))} Continuous current allowing 125% I_{Hd} for 1 minute every 10 minutes at 40 °C.
P_{Hd}	Typical motor power in heavy-duty use.

The ratings apply for the frames R1 to R9 up to +40 °C in enclosure class 21.

The ratings apply for the frames R10 to R11 up to +40 °C in enclosure class IP00/IP20.

For derating at higher altitudes, temperatures, switching frequencies or enclosure classes, see the HW manuals, document codes: 3AXD50000018826 and 3AXD50000015497.

Drive modules, ACS580-04 (3-phase supply voltage range 380-480 V)													
Frame type	Frame size	3-phase, $U_N = 400$ V							3-phase, $U_N = 480$ V				
		Nominal ratings		Light-duty use	Heavy-duty use		Max. output current	Light-duty use	Heavy-duty use		Max. output current		
		P_N (kW)	I_N (A)	I_{Ld} (A)	P_{Ld} (kW)	I_{Hd} (A)	P_{Hd} (kW)	I_{max} (A)	I_{Ld} (A)	P_{Ld} (hp)	I_{Hd} (A)	P_{Hd} (hp)	I_{max} (A)
ACS580-04-505A-4	R10	250	505	485	250	361	200	560	483	400	361	300	560
ACS580-04-585A-4	R10	315	585	575	315	429	250	730	573	450	414	350	730
ACS580-04-650A-4	R10	355	650	634	355	477	250	730	623	500	477	400	730
ACS580-04-725A-4	R11	400	725	715	400	566	315	1020	705	600	566	450	850
ACS580-04-820A-4	R11	450	820	810	450	625	355	1020	807	700	625	500	1020
ACS580-04-880A-4	R11	500	880	865	500	725 ^{*)}	400	1100	807	700	625	500	1020

Cabinet-built drives, ACS580-07 (3-phase supply voltage range 380-480 V)													
Frame type	Frame size	3-phase, $U_N = 400$ V							3-phase, $U_N = 480$ V				
		Nominal ratings		Light-duty use	Heavy-duty use		Max. output current	Light-duty use	Heavy-duty use		Max. output current		
		P_N (kW)	I_N (A)	I_{Ld} (A)	P_{Ld} (kW)	I_{Hd} (A)	P_{Hd} (kW)	I_{max} (A)	I_{Ld} (A)	P_{Ld} (hp)	I_{Hd} (A)	P_{Hd} (hp)	I_{max} (A)
ACS580-07-0145A-4	R6	75	145	138	75	105	55	178	124	100	96	75	178
ACS580-07-0169A-4	R7	90	169	161	90	145	75	247	156	125	124	100	247
ACS580-07-0206A-4	R7	110	206	196	110	169	90	287	180	150	156	125	287
ACS580-07-0246A-4	R8	132	246	234	132	206	110	350	240	200	180	150	350
ACS580-07-0293A-4	R8	160	293	278	160	246 ^{***)}	132	418	260	200	240	150	418
ACS580-07-0363A-4	R9	200	363	345	200	293	160	498	361	300	302	250	542
ACS580-07-0430A-4	R9	250	430	400	250	363 ^{***)}	200	617	414	350	361	300	542
ACS580-07-0505A-4	R10	250	505	485	250	361	200	560	483	400	361	300	560
ACS580-07-0585A-4	R10	315	585	575	315	429	250	730	573	450	414	350	730
ACS580-07-0650A-4	R10	355	650	634	355	477	250	730	623	500	477	400	730
ACS580-07-0725A-4	R11	400	725	715	400	566	315	1020	705	600	566	450	850
ACS580-07-0820A-4	R11	450	820	810	450	625	355	1020	807	700	625	500	1020
ACS580-07-0880A-4	R11	500	880	865	500	725 ^{*)}	400	1100	807	700	625	500	1020

Nominal ratings, ACS580-04 and ACS580-07

I_N	Rated current available continuously without overloadability at 40 °C.
P_N	Typical motor power in no-overload use.

Maximum output current

I_{max}	Maximum output current. Available for 2 seconds at start.
-----------	---

Light-overload use

I_{Ld}	Continuous current allowing 110% I_{Ld} for 1 minute every 10 minutes at 40 °C.
P_{Ld}	Typical motor power in light-duty use.

Heavy-duty use

I_{Hd}	Continuous current allowing 150% I_{Hd} for 1 minute every 10 minutes at 40 °C. ^{*)} Continuous current allowing 140% I_{Hd} for 1 minute every 10 minutes at 40 °C. ^{***)} Continuous current allowing 130% I_{Hd} for 1 minute every 10 minutes at 40 °C. ^{***)} Continuous current allowing 125% I_{Hd} for 1 minute every 10 minutes at 40 °C.
P_{Hd}	Typical motor power in heavy-duty use.

The ratings apply for the frames R6 to R9 up to +40 °C in enclosed IP class 21.

The ratings apply for the frames R10 to R11 up to +40 °C in enclosed IP00/IP20.

For derating at higher altitudes, temperatures or switching frequencies, see the HW manuals, document codes: 3AXD50000018826, 3AXD50000015497, 3AXD50000045815 and 3AXD50000032622.

Ratings, types and voltages

3-phase, $U_N = 230$ V (range 200 to 240 V). The power ratings are valid at nominal voltage 230 V (0.75 to 75 kW)

Drive type	Frame size	Nominal ratings		Light-duty use		Heavy-duty use		Maximum output current
		I_N (A)	P_N (kW)	I_{Ld} (A)	P_{Ld} (kW)	I_{Hd} (A)	P_{Hd} (kW)	I_{Max} (A)
ACS580-01-04A7-2	R1	4.7	0.75	4.6	0.75	3.5	0.55	6.3
ACS580-01-06A7-2	R1	6.7	1.1	6.6	1.1	4.6	0.75	8.9
ACS580-01-07A6-2	R1	7.6	1.5	7.5	1.5	6.6	1.1	11.9
ACS580-01-012A-2	R1	12	3	11.8	3	7.5	2.2	19.1
ACS580-01-018A-2	R1	16.9	4	16.7	4	10.6	3.0	22
ACS580-01-025A-2	R2	24.5	5.5	24.2	5.5	16.7	4.0	32.7
ACS580-01-032A-2	R2	31.2	7.5	30.8	7.5	24.2	5.5	43.6
ACS580-01-047A-2	R3	46.7	11	46.2	11	30.8	7.5	62.4
ACS580-01-060A-2	R3	60	15	59.4	15	46.2	11	83.2
ACS580-01-089A-2	R5	89	22	88	22	74.8	18.5	135
ACS580-01-115A-2	R5	115	30	114	30	88.0	22.0	158
ACS580-01-144A-2	R6	144	37	143	37	114	30	205
ACS580-01-171A-2	R7	171	45	169	45	143	37	257
ACS580-01-213A-2	R7	213	55	211	55	169	45	304
ACS580-01-276A-2	R8	276	75	273	75	211	55	380

Nominal ratings

I_N	Rated current available continuously without overloadability at 40 °C.
P_N	Typical motor power in no-overload use.

Maximum output current

I_{max}	Maximum output current. Available for 2 seconds at start, then as long as allowed by drive temperature.
-----------	---

Light-overload use

I_{Ld}	Continuous current allowing 110% I_{Ld} for 1 minute every 10 minutes at 40 °C.
P_{Ld}	Typical motor power in light-overload use.

The ratings apply for the frames R1 to R9 up to +40 °C in enclosed IP21/IP55.

For derating at high altitudes, temperatures or switching frequencies, see the user's HW manual, document code: 3AXD50000035866.

Overloadability and output current illustration

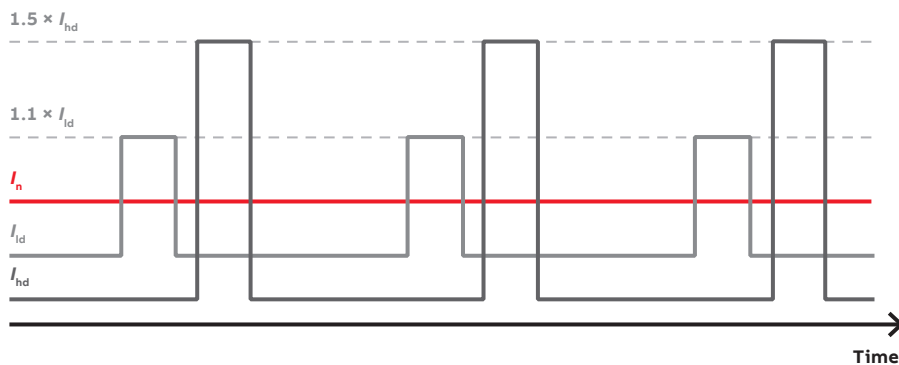

Definition	ACS580
No overload	I_n
110% overload 1 min / 10 minutes	I_{ld}
150% overload 1 min / 10 minutes	I_{hd}



Easiness on a whole new level



The assistant control panel's intuitive user interface, assistants and ready-made macros offer simplicity for everyday life. The panel guides you through commissioning without a need to know any drive parameters and helps in unclear situations.

Assistant control panel, ACS-AP-S

Set up the drive, fine-tune motor control and monitor values that matter using the assistant control panel, delivered as standard with all ACS580 drives. The assistant control panel can also be used with the ACS480 and the ACS380.

Commission without a hassle

Select language, set time and date, name the drive, enter motor values, test rotating the motor.

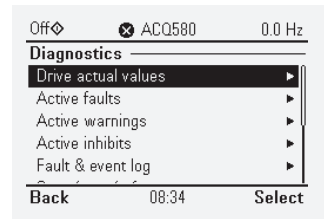
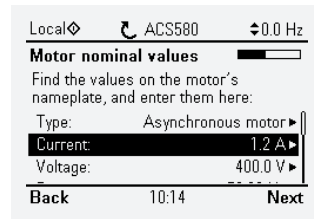
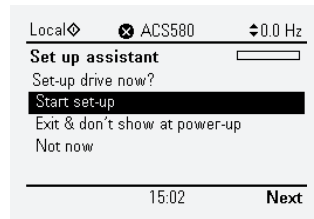

Primary settings

Select ready-made macros, perform ID-run, fine-tune settings related to e.g. ramps, limits, PIDs, fieldbuses, reset to defaults.

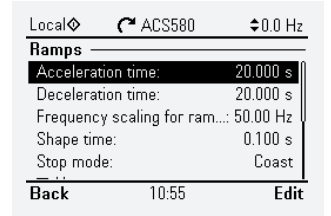
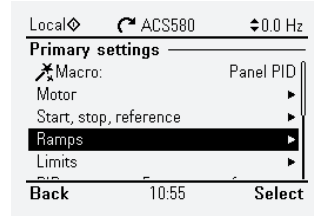
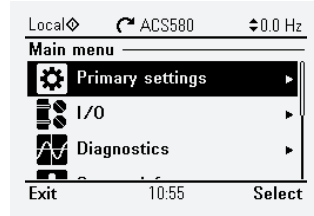

Input/output menu

Set and monitor your input/output (I/O) connections for real-time diagnostics

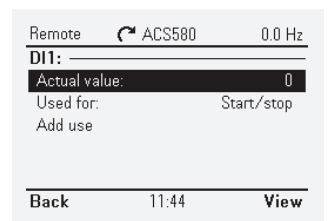
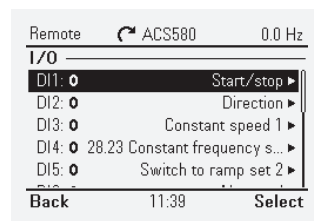
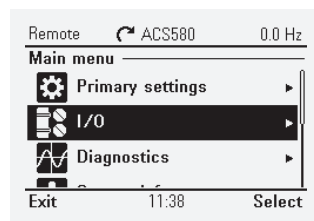

Home view displays

Monitor the values that are the most important to you. You can select values for monitoring from a ready-made list or choose user-defined parameters.

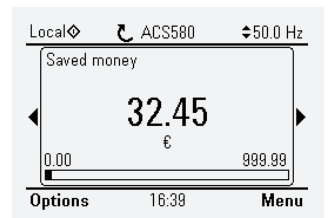
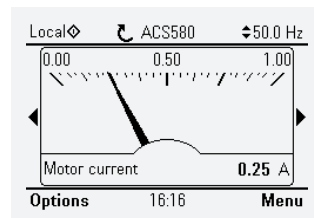
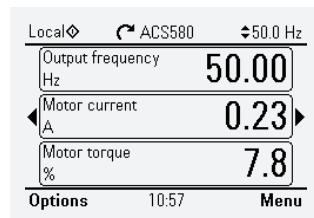

Help button

The help button provides more information about your selection and it can be pressed in any view.

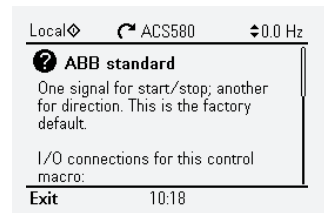
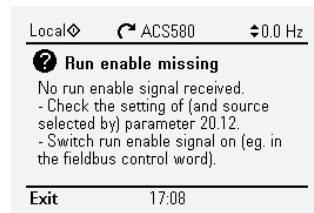
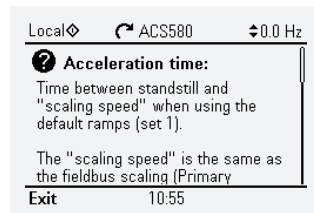

Control panel options and mounting kits

The standard delivery of the ACS580 includes the assistant control panel (requires the +J400 code), but it can be also replaced by other control panels.



Bluetooth control panel, ACS-AP-W *)

The optional Bluetooth panel enables connection with the Drivetune mobile app. The app is available for free from Google Play and the Apple App store. Together with the Drivetune app and the Bluetooth panel, users can, for example, commission and monitor the drive remotely.



Control panel mounting platform, DPMP-01

This mounting platform is for surface mountings. This also requires RDUM-01 (blank control panel with the RJ-45 connector) and a control panel (assistant, basic, Bluetooth or industrial).



Industrial control panel, ACS-AP-I *)

The industrial control panel is compatible with all ABB drives, making it simple to use a single panel with different products.



Control panel mounting platform, DPMP-02

This mounting platform is for flush mountings. This also requires RDUM-01 (blank control panel with the RJ-45 connector) and a control panel (assistant, basic, Bluetooth or industrial).



Basic control panel, ACS-BP-S

The icon-based control panel supports users with parameter backup, settings and fault tracking in basic operation.



Door mounting kit, DPMP-EXT

The door mounting kit is ideal for cabinet installations. A kit for one drive includes one DPMP-02 and one CDPI-01 (blank control panel cover with RJ-45 connector). If a different control panel than the assistant panel is desired for cabinet door installation, it must be ordered separately.



Panel bus adapter, CDPI-01

The panel bus adapter is an ideal choice if there is a need to control multiple drives with a single control panel. The panel bus adapter offers also simplicity for cabinet installations as by using it the control panel can be installed on the cabinet door and the drive can be operated easily and safely.



Control panel mounting kit for outdoor installation DPMP-04/05

Enables control panel outdoor mounting thanks to IP66 protection class, UV resistance and IK07 impact protection rating.



Blank control panel, CDUM-01

The blank control panel can be used for covering the control panel slot if no control panel or panel bus adapter is needed.

Door mounting and daisy chaining

Improve safety and leverage the full potential of the ACS580 control panel options with a door mounting kit and panel bus adapter.



Door mounting fosters easy operation and safety. It enables you to operate the drive without opening the cabinet door, saving time and keeping all the electronics behind the closed door. Up to 32 drives can be connected to one

control panel for even easier and quicker operation. When daisy chaining the drives, you need only one assistant control panel. The rest of the drives can be equipped with panel bus adapters.

Cabinet door

Door mounting kit, DPMP-EXT

The kit includes a surface mounting platform for the drive's control panel, panel bus adapter (CDPI-01) and an RJ-45 cable for connecting the control panel and the panel bus adapter.

Assistant control panel

The assistant control panel is delivered as standard with the ACS580 drives. Also a Bluetooth or industrial control panel can be used.

RJ-45 cable for daisy chaining drives

Panel bus adapter, CDPI-01

The panel bus adapter can be ordered with a plus code +J424 or with an MRP code 3AXD50000009843 as a loose option.



Cabinet, outside

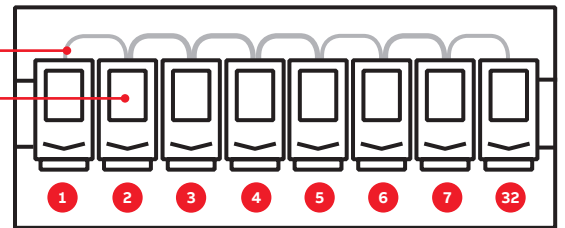

Cabinet, inside

Control panel options

The ACS-AP-S assistant control panel (plus code +J400) is included as standard in the delivery. If no code is mentioned in the ACS580 order, the assistant control panel is automatically added to the delivery. It can be replaced by one of the other +Jxxx options listed below.

MRP code	Plus code	Description	Type designation
3AUA0000064884	+J400	Assistant control panel **)	ACS-AP-S
3AXD50000025965	+J429	Control panel with Bluetooth interface */**)	ACS-AP-W
3AUA0000088311	+J425	Industrial assistant control panel */**)	ACS-AP-I
3AXD50000028828	+J404	Basic control panel**)	ACS-BP-S
3AXD50000009843	+J424	Blank control panel cover (no control panel delivered)	CDUM-01
3AXD50000004419	-	Panel bus adapter	CDPI-01
3AUA0000108878	-	Control panel mounting platform (flush mounted, requires also panel bus adapter on the drive)	DPMP-01
3AXD50000009374	-	Control panel mounting platform (surface mounted, requires also panel bus adapter on the drive)	DPMP-02
3AXD50000016230	-	Control panel mounting platform option, only for ACS580-04 modules	DPMP-03
3AXD50000217717	-	Control panel mounting kit for outdoor installation	DPMP-04
3AXD50000240319	-	Control panel mounting kit for outdoor installation, only for ACS580-04/34	DPMP-05
3AXD50000010763	-	Door mounting kit for the panel (for one drive, contains both DPMP-02 and CDPI-01)	DPMP-EXT

*) Compatible with ACS880 drives
 **) Compatible with the ACS480 and ACS380



Higher enclosure class for cabinet-free installations even in harsh conditions

Don't let dust, moisture or dirt interrupt your processes and drag down productivity. ACS580 IP55/UL Type 12 units keep your systems running even in tough conditions.



Compact units for rough environments
 The ACS580 IP55 and UL Type 12 units are an ideal choice for harsh environments, where impurities, such as dust or dirt waft in the air. Typical harsh environments include textile, cement, metal and wood processing industries and harsh outdoor conditions in desert and tropical environments. Higher protection class ensures smooth processes by reducing downtime.

These units can be installed directly on the wall closer to the motor, which provides flexibility and simplifies installation. The robust, protective design ensures that no additional enclosures or components, such as dust filters and fans, are needed.

Be productive, save money and keep it simple
 If there's a job assignment to build an outdoor swimming pool, the construction employees need to have the right tools and equipment to be successful and productive. A shovel and garden hose are obviously not the right choice for the job. The same applies to your processes: in order to perform the job well, you need to have the right equipment for it.

If the environment around your processes includes impurities, drives with lesser enclosure ratings are more likely to fail because they are not designed for harsh environments. A failure causes an interruption and instantly cuts down productivity and adds costs. Coated control boards of the ACS580 IP55/UL Type 12 units, increased use of plastics with smart design, and fully gasketed control panel section that maintains the IP rating even if the control panel

Ordering codes	Description
+B056	IP55/UL Type 12 unit (R1-R9)
+F278	Integrated main switch (R1-R5) *)
+E223	Integrated C1 filter (R1-R5) *)
+F316	Integrated main switch and C1 filter (R1-R5) *)

*) Integrated into the R1 and R2, external box for the R3, R4 and R5.

is removed help keep your processes up and running in tough environments.

Installing the drive closer to the motor allows shorter motor cables to be used. Shorter cables not only cost less and are easier to handle, but they make it easier to fulfill EMC requirements and reduce the need for additional filters.

Cost reductions take place also by eliminating the need for a cabinet. IP55/UL Type 12 enclosure provides protection from dust and jetting water from any direction. Speed-controlled main cooling fans maintain optimal drive operating temperatures without a need for external cooling. Keeping the drive at optimal temperature increases the lifetime of the drive.

In addition, the IP55/UL Type 12 units reduce maintenance costs compared to cabinet-mounted drives because of the elimination of air filters. The cabinet air filters need to be replaced on a regular basis and if they're not cleaned or taken care of properly, the cabinet temperature may rise and cause issues in the process. In these situations a maintenance engineer may need to open the cabinet door to identify the root cause.

Exploring the root cause is extra work and an open cabinet door instantly decreases safety, exposes all the components to the impurities and interrupts your processes. All these costs can be avoided with cabinet-free installation.

Integrated main switch and EMC C1 filter for further safety improvements and cost reductions

The ACS580 IP55/UL Type 12 units can be ordered with an integrated main switch and/or EMC C1 filter (R1-R5). The integrated main switch further simplifies the installation and improves safety as it ensures a correct drive is being disconnected instead of another one. The switch can be padlocked with three padlocks and in case all padlocks are used, three people need to agree and observe together whether it is safe to connect the drive before the drive can be connected.

Having the EMC C1 filter embedded to the drive, there is no need to order, install and test it separately. The integrated filter is already tested with the drive and it is prewired so there is no need for additional cabling.

Ready made accessories for simplified cabinet assembly

Installing ACS580-01 drive modules into Rittal VX25 cabinets is made easier with mechanical and electrical accessory kits. The ready made accessories will save time in design work and reduce the building time to enable faster cabinet delivery. This will enable machine builders, system integrators and panel builders to built drive packages using their own cabinet design with ABB technology.

For more information and ordering details, please see manual supplement 3AXD50000523191.



ACS580-07 cabinet-built drives

Effortless process automation in a ready-made cabinet

The ACS580-07 is part of the all-compatible family and a cabinet-built extension to the ACS580 series. They are suited for many different applications, easy to use, order and maintain, and they are quickly available. The simple and robust design ensures reliable operation even in harsh environments. The cabinets are compact in size, including flange mounting (R6-R9) and optimized cooling system as standard.

For many purposes: The ACS580-07 is ready to control many applications including, mixers, extruders, compressors, centrifuges, and fans, also installed in potentially explosive environment.



Easy to order: An EMC filter, chokes, assistant control panel, Modbus RTU, STO and installation tools are included as standard, and in addition there are several options available to further fulfill your needs. (See page 57)



Fast to get: Cabinet-built ACS580-07 drives are delivered fast from the factory.



Easy to use: Application control is easy to setup through the assistant control panel. Also other all-compatible ACS580 user interfaces can be used with the ACS580-07. (See page 25)



Easy to maintain: Smartly positioned fans and filters ensure the longevity of the drive and its components. When it is time to do maintenance, the necessary components are in easily accessible locations.



EMC tested: All cabinet-built ACS580-07 drives are tested by 3rd party facilities and have certified results for emitted radiations in accordance to IEC 61800-3ED.2:2004+A1(2011). R6-R9 are classified as C2 and R10-R11 as C3.



Thermal tested: The thermal properties are tested in accordance to IEC 61800-5-1:2007 and UL61800-5-1 1st ed. 2012 standards to ensure the environment and operators stay safe in all operating conditions. Be it a premature fan failure or clogged environmental filters to restrict the cooling capabilities, the tests verify that the equipment is self-protecting it at all times.



Adaptable to harsh environments: High enclosure classes and unique cooling system ensure the units stay cool even in harsh environments with air pollution.



Factory acceptance test (FAT): For ABB the reliability and quality of the drives is the utmost important. To ensure that the drive solutions meet the specifications and the customer expectations, ABB offers to have a factory acceptance test (FAT) in drives factory. Remote FAT or visual inspection is possible via online services.



Frame sizes R6-R9

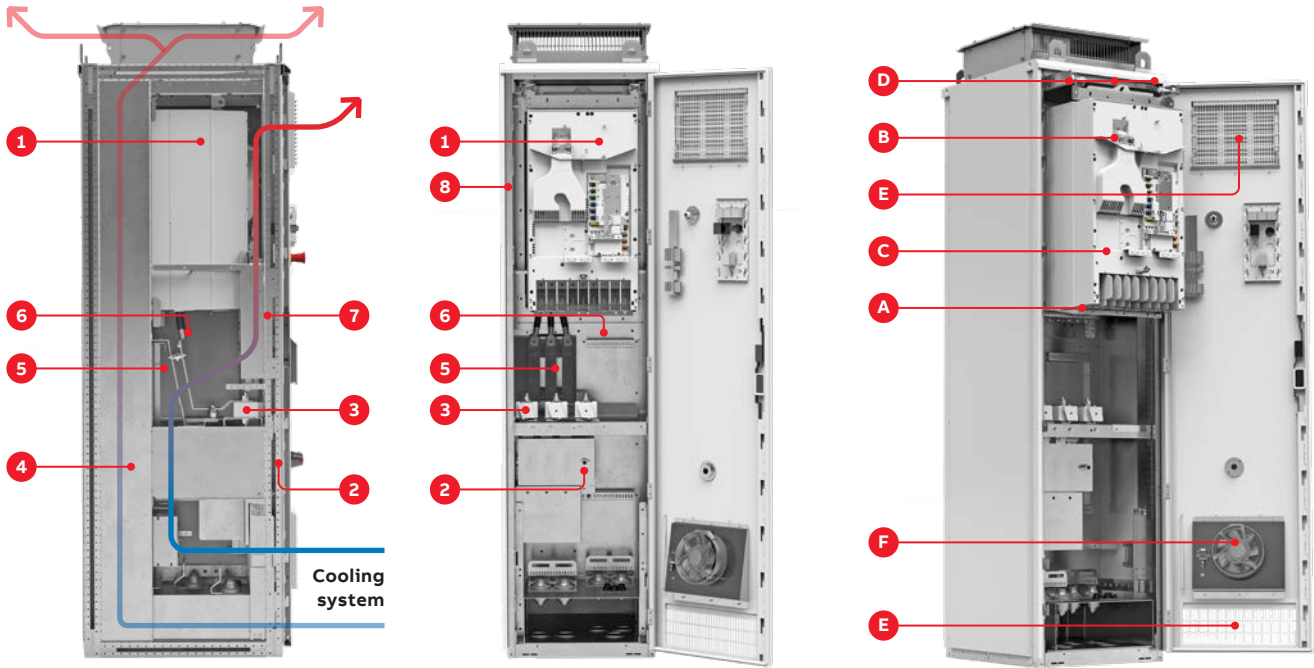

Frame sizes R10-R11

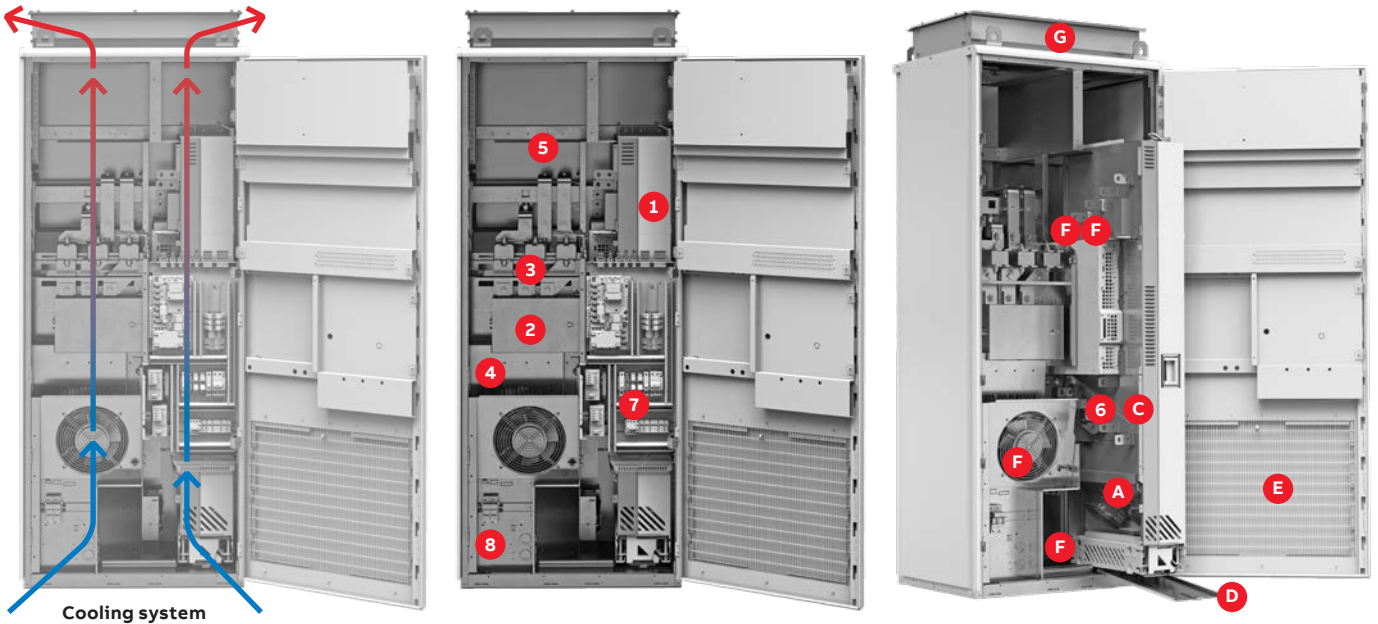

Cabinet components

- 1. Module
- 2. Main switch or MCCB, option +F289
- 3. Fuses
- 4. Space for optional du/dt filter or cabinet resistors
- 5. Space for a line contactor option +F250
- 6. Common mode filter allocation
- 7. Space for safety, ATEX or external power supply options
- 8. Space for options +M600...+M605

Maintenance operation components

- A Main fans
- B Auxiliary fans
- C Capacitors (inside the module)
- D Rails and ramp supporting maintenance operation
- E Filters for dust and external components
- F Other supporting fans for R10 and R11
- G Roof top for R10 and R11 (only IP54)

Commissioning, programming and customization tools

Your engineering efficiency is boosted with our commissioning and programming tools, giving you the optimal solution to perform virtualization, planning, commissioning and maintenance.

Safe configuration for unpowered drives

The CCA-01 cold configuration adapter provides a serial communication interface for unpowered ACS580 drives. With the adapter, safety isolation of both serial communication and control board power supply is possible. The power supply is taken from a PC USB port.

Cold configurator



Users can download the software and parameters to drives without powering the drive.

MRP code	Description	Type designation
3AXD50000019865	Cold configurator adapter, packed kit	CCA-01

Drive Composer

The Drive Composer PC tool offers fast and harmonized setup, commissioning and monitoring for all-compatible drives. The free version of the tool provides startup and maintenance capabilities and gathers all drive information, such as parameter loggers, faults, backups and lists, into a support diagnostics file. Drive Composer pro provides additional features such as custom parameter windows, graphical control diagrams of the drive's configuration, and improved monitoring and diagnostics.

Drive Composer



Entry level (free)	Pro level
Basic functionality	Entry-level features
Parameter setting	Networked drives
Point-to-point connection	Control diagrams
Simple monitoring	Data logger(s)
Supports adaptive programming	Graphical safety setup
Adaptive programming in Demo mode	Adaptive (block) programming
–	Multiple backup and restore
–	Drive configuration by using virtual drive

Link/MRP codes	Description	Type designation
new.abb.com/drives/software-tools/drive-composer	Link to download free Drive Composer entry	–
9AKK105408A3415	Drive Composer entry PC tool (document)	–
3AUA0000108087	Drive Composer pro PC tool (single user license)	DCPT-01
3AUA0000145150	Drive Composer pro PC tool (10 users license)	DCPT-01
3AUA0000145151	Drive Composer pro PC tool (20 users license)	DCPT-01

Automation Builder

ABB Automation Builder is the integrated software suite for machine builders and system integrators wanting to automate their machines and systems in a productive way. Combining the tools required for configuring, programming, debugging and maintaining automation projects in a common, intuitive interface, Automation Builder addresses the largest single cost element of most of today’s industrial automation projects: software.

Automation Builder



ABB Automation Builder covers the engineering of ABB PLCs, safety PLCs, control panels, drives, motion and robots.

The common engineering tool Automation Builder is used for drive and PLC programming and configuration.

Automation Builder is available in Basic, Standard and Premium editions, fitting the needs of small projects and managing the challenges of many and large projects for OEM and system integrators.

Adaptive programming

Adaptive programming software, embedded inside the drive, is especially handy when there is a need to distribute some of the machine’s control logic to the drive. Adaptive programming brings energy savings when the drive is adjusted to control the application optimally. You can use our Drive Composer PC tool to set up the adaptive programming. The drive also offers sequence programming capabilities. Adaptive programming makes it possible to enhance the existing application control program to precisely fit users’ application needs. The program is also handy for ensuring that the drive’s electrical design is connected as it should be with working drive signals.

Adaptive programming

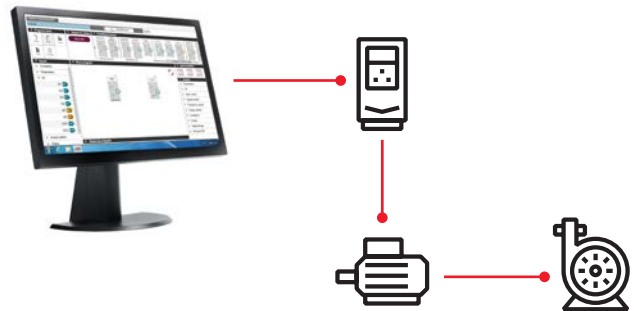

Drive manager

Drive Manager for SIMATIC (DM4S-01) is a plug-in device tool that can be easily installed, for example, in the STEP 7 and TIA Portal. It utilizes the TCI interface of the SIMATIC PLC to communicate with drives connected to PROFIBUS or a PROFINET network.

Drive Manager for SIMATIC offers several useful, ready-made features that simplify the setup of ABB low voltage drives used in combination, for example, with SIMATIC S7 PLCs including:

- Network connection over PROFIBUS and PROFINET (single point of access)
- Online and offline configuration of drives
- Monitoring of actual drive values
- Export to/import from the drive-dedicated PC tools
- Saving drive parameter settings within the SIMATIC PLC project

Drive manager

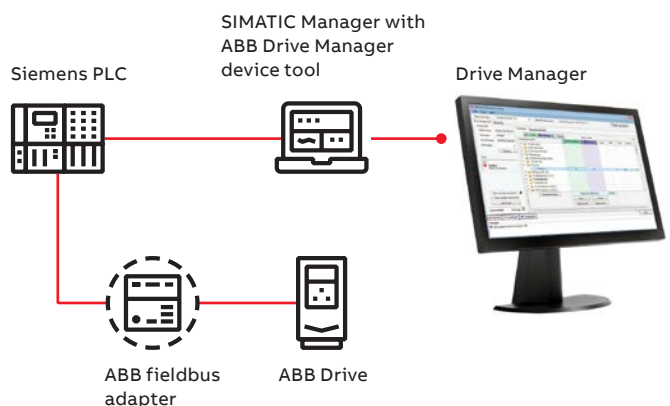

Communication and connectivity

Options

Fieldbus adapter modules

The ACS580 comes with Modbus RTU fieldbus interface as standard, and it is also compatible with a wide range of additional fieldbus protocols. Fieldbus communication reduces wiring costs compared to traditional hardwired input/output connections. The fieldbus options can be installed into a slot one (1).

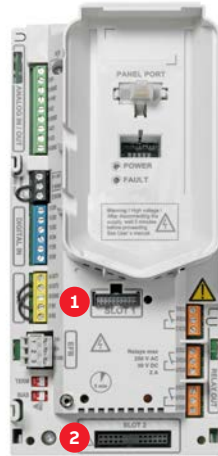

Input/output extension modules

Standard input and output can be extended by using optional analog and digital input/output extension modules. The modules are easily installed in the extension slot two (2) located on the drive.

Fieldbus options



Plus code	MRP code	Fieldbus protocol	Adapter
+K451	68469341	DeviceNet™	FDNA-01
+K454	68469325	PROFIBUS DP, DPV0/DPV1	FPBA-01
+K457	68469376	CANopen®	FCAN-01
+K458	3AUA0000031336	Modbus RTU	FSCA-01
+K462	3AUA0000094512	ControlNet	FCNA-01
+K469	3AUA0000072069	EtherCAT®	FECA-01
+K470	3AUA0000072120	POWERLINK	FEPL-02
+K490	3AXD50000192786	Two port Ethernet/IP	FEIP-21
+K491	3AXD50000049964	Two port Modbus/TCP	FMBT-21
+K492	3AXD50000192779	Two port PROFINET IO	FPNO-21
+Q986	3AXD50000112821	Safety functions fieldbus Profisafe module	FSPS-21



Options









Plus code	MRP code	Description	Type designation
+L501	3AXD50000004420	External 24 V AC and DC 2 x RO and 1 x DO	CMOD-01
+L523	3AXD50000004418	External 24 V and isolated PTC interface	CMOD-02
+L512	3AXD50000004431	115/230 V digital input 6 x DI and 2 x RO	CHDI-01
+L537	3AXD50000033578	ATEX-certified PTC interface, Ex II (2) GD and external 24 V ^{*)}	CPTC-02
+L500	3AXD50000137954	Bipolar analog I/O adapter module ^{**)}	CBAI-01
+L525	3AXD50000709243	Analogue signal extension 3 x AI and 2 x AO	CAIO-01

^{*)} For further information please see pages 48-49
^{**)} No additional analog input/output is offered

Embedded fieldbus interface

Fieldbus protocol	Features	Connector type	+Code/ MRP code/ Typecode
 Modbus (RTU)	<ul style="list-style-type: none"> The embedded interface acts as a Modbus/RTU server with support for ABB drives profiles 	Screw terminal	As standard

The F-series fieldbus adapter modules

Fieldbus protocols	Features	Connector type	+Code/ MRP code/ Typecode
 EtherNet/IP	<ul style="list-style-type: none"> The interface module acts as an EtherNet/IP™ server with support for ODVA AC/DC drive and ABB drive profiles Supports both explicit messaging where each attribute of a class is set individually, and implicit messaging using input and output instances Support device-level ring (DLR) Has 2 RJ45 connections with an integrated switch Has Add-On Instructions available 	2 x RJ45	+K490 3AXD50000192786 (FEIP-21)
 PROFINET	<ul style="list-style-type: none"> PROFINET® IO is an open standard for Industrial Ethernet Used from process automation to motion control, as well as for functional-safety solutions Supports PROFIdrive and ABB drive profiles Has 2 RJ45 connections with an integrated switch S2 System redundancy Supports ring topology with Media Redundancy Protocol (MRP) Supports PROFIsafe with optional FSO-12/21 for ACS880 and with optional FSPS-21 for ACS380, ACS580 and ACS880 	2 x RJ45	+K492 3AXD50000192779 (FPNO-21)
 EtherCAT	<ul style="list-style-type: none"> EtherCAT® is a real-time Ethernet master/slave fieldbus system The EtherCAT slave devices read the data addressed to them while the telegram passes through the device enabling fast real-time communication The telegrams are only delayed by a few nanoseconds Supports CiA 402 and ABB drives profiles 	2 x RJ45	+K469 3AUA0000072069 (FECA-01)
 CANopen	<ul style="list-style-type: none"> CANopen® is a popular industrial communication network originally designed for motion-oriented machine control networks, such as handling systems Supports both cyclic and acyclic event driven communication. This makes it possible to reduce the bus load to a minimum and maintain short reaction times. Supports CiA 402 and ABB drive profiles 	Screw terminal D-SUB 9	+K495 (BCAN-11) 3AXD50000033816 +K457 68469376 (FCAN-01)
 ETHERNET POWERLINK	<ul style="list-style-type: none"> Ethernet POWERLINK is a real-time protocol for standard Ethernet The protocol guarantees transfer of time-critical data in very short cycles with configurable response time Supports CiA 402 and ABB drives profiles 	2 x RJ45	+K470 3AUA0000072120 (FEPL-02)
 ControlNet	<ul style="list-style-type: none"> ControlNet™ is an open control network that meets the demands of real-time, high-throughput applications Supports controller-to-controller interlocking and real-time control of I/O, drives and valves Provides control networking in discrete and process applications including high-availability Supports ODVA AC/DC Drive and ABB drives profiles Has add-On Instructions available 	2 x 8P8C	+K462 3AUA0000094512 (FCNA-01)
 DeviceNet	<ul style="list-style-type: none"> DeviceNet™ offers robust, efficient data handling since it is based on a Produce/Consume model Uses CAN (Controller Area Network) as the backbone technology and defines an application layer to cover a range of device profiles Supports ODVA AC/DC drive and ABB drives profiles 	Screw terminal	+K451 68469341 (FDNA-01)
 Modbus (TCP)	<ul style="list-style-type: none"> The interface module acts as a Modbus® TCP server with support for ABB drive profiles Common read/write single and multiple register function codes are supported Has 2 RJ45 connections with an integrated switch 	2 x RJ45	+K491 3AXD50000049964 (FMBT-21)
 PROFIBUS	<ul style="list-style-type: none"> PROFIBUS® DP is the most widely used industrial network ABB drives support PROFIBUS DP-V0 and DP-V1 Supports PROFIdrive and ABB drives profiles 	Screw terminal	+K458 3AUA0000031336 (FSCA-01)
 PROFIBUS	<ul style="list-style-type: none"> PROFIBUS® DP is the most widely used industrial network ABB drives support PROFIBUS DP-V0 and DP-V1 Supports PROFIdrive and ABB drives profiles 	D-SUB 9	+K454 68469325 (FPBA-01)

Safety options

Integrated safety

Integrated safety reduces the need for external safety components, simplifying configuration and reducing installation space. The safety functionality is a built-in feature of the ACS580, with Safe Torque Off (STO) as standard. ACS580 can also be part of PROFIsafe over PROFINET network, where safety PLC is controlling the STO or Safe Stop 1, time controlled, SS1-t functionality. This connectivity and functionality can be done by using the FSPS-21 option module.

The drives' functional safety is designed in accordance with EN/IEC 61800-5-2 and complies with the requirements of the European Union Machinery Directive (2006/42/EC). The safety functions are certified by TÜV Nord and comply with the highest safety performance level (SIL 3/PL e) for machinery safety. It is possible to install the safety modules also afterwards to the drive.

PROFIsafe safety functions module FSPS-21

The FSPS-21 module has integrated PROFIsafe, safety functions and PROFINET IO connection. The ready-made safety functions make safety configuration in the drive unnecessary. The module supports STO and SS1-t safety functions. It is used together with a safety PLC that supports PROFIsafe over PROFINET communication.

For more information see FSPS-21 PROFIsafe safety functions module web page at new.abb.com/drives/functional-safety



Safe Torque Off (STO)

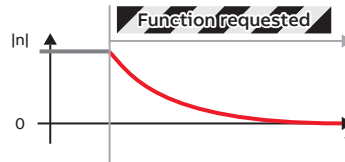

STO is the basic foundation of drive-based functional safety, as it brings a drive safely to no-torque state making the motor coast to stop. Integrated STO-function simplifies the safety circuit as external components are not needed to safely stop the application.

- **STO** is a standard safety function in all ABB drives.
- Typically used for prevention of an unexpected startup
- (EN ISO 14118) of machinery or for an emergency stop, fulfilling stop category 0 (EN 13850 / IEC 60204-1).

Safe Stop 1, time controlled (SS1-t)

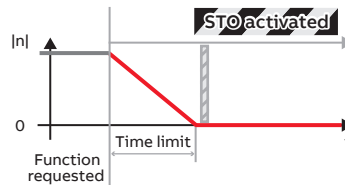

Safe Stop 1 stops the motor safely with a controlled ramp stop and stop time monitoring. SS1-t initiates the ramp stop from the drive and activates STO when speed reaches zero. If the drive is not decelerating to zero speed within the time limit, the STO function is activated. SS1-t is typically used in applications where motion must be stopped quickly and safely before switching to a no-torque state.

- **SS1-t** stops the motor safely, using a controlled ramp stop and then activates the STO function.
- **SS1-t** can be used to implement an Emergency stop, fulfilling stop category 1 (EN/IEC 60204-1).



PROFIsafe safety functions module FSPS-21		
Option code	Ordering code	Module
+Q986	3AXD50000112821	FSPS-21

Note: This module isn't compatible with other fieldbus option modules for ACS380 and ACS580 drives

Example: SS1-t

Safety function module FSPS-21, functionality cycle

0. Drive running

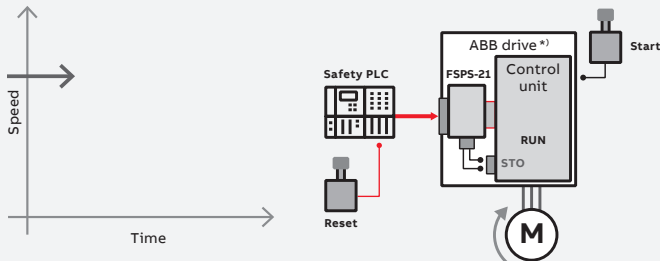

1. Safety PLC – safety function request to the FSPS-21

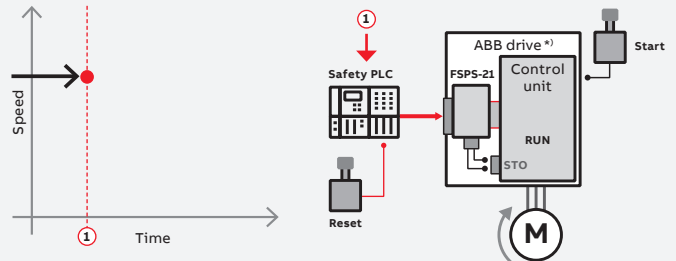

2. SS1-t, safety functions request / start of monitoring

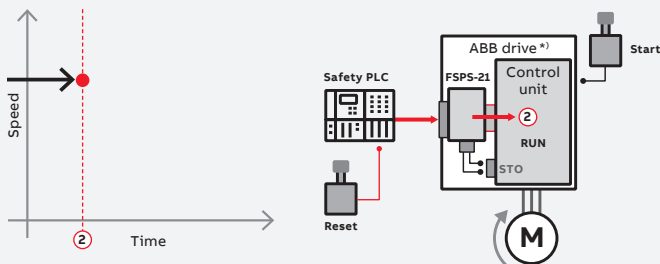

3. Transition and time monitoring of the SS1-t

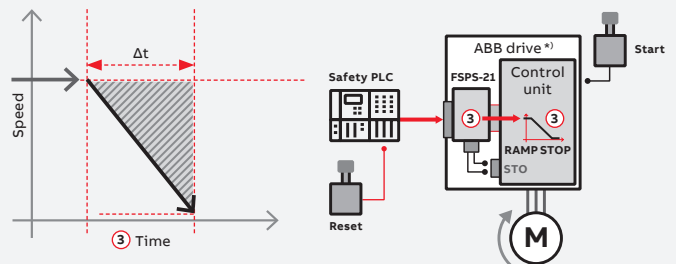

4. Zero speed or SS1-t time limit reached / STO is opened

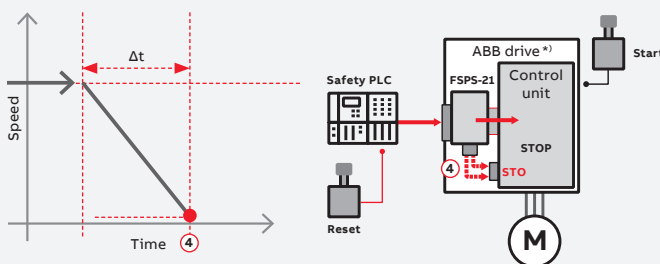

5. Safe state / STO is open

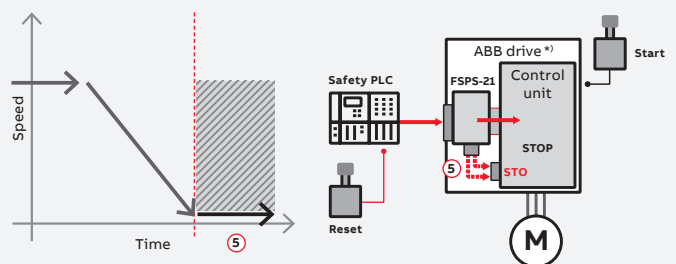

6. Safety function request removed / reset / STO is closed

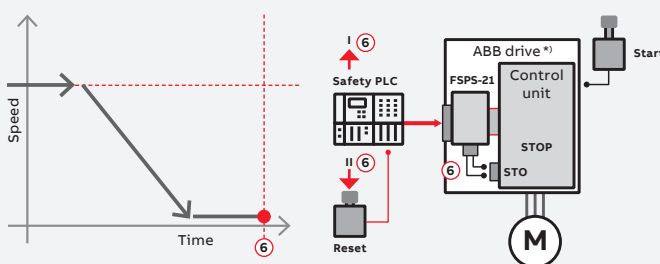

7. Start – return to normal operation

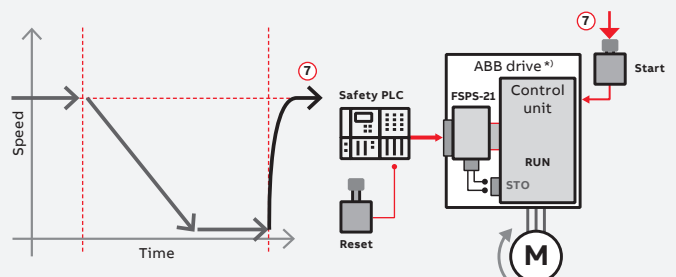

^{*)} The ABB drive can be ACS380, ACS580 or ACS880

ABB Ability™ Digital Powertrain

Condition monitoring for drives and rotating equipment

Accurate, real-time information about powertrain events. When you have the facts, you can make the right decisions.

ABB Ability™ Digital Powertrain

The ABB Ability Digital Powertrain enables you to remotely monitor the health and performance of entire powertrains including drives, motors and applications, such as pumps. The data collected from the connected equipment can be accessed and analyzed remotely, providing a better understanding of the health and energy efficiency of the entire process.

ABB Ability™ Condition Monitoring for drives

ABB Ability Condition Monitoring for drives is a key element of the Digital Powertrain. The services are designed to provide key information about drive events and changes in behavior to ensure your equipment is always available, reliable and well maintained.

The service can be tailored to fit your needs. Our standard package for condition monitoring for drives gives you industry leading monitoring capabilities – whether you want to view the drive status through ABB's Internet portal or integrate this data with your existing monitoring systems.

The standard package includes the following services:

- Condition Monitoring
- Alarm Management
- Asset Health
- Team Support
- Backup Management

The standard package can be supplemented with optional services:

- Condition-Based Maintenance
- Offline Data Collection
- Expert Reports
- Remote Assistance
- Condition monitoring of your entire powertrain



Key benefits



Solid fact-based decision making

Get the facts, and the history, to help run your operations better and more safely.



Always stay one step ahead of problems

Recognize early signs of possible failures and assess the risks before they turn into serious operational issues.



Find the root cause of process issues

Remotely access data from ABB drives built-in sensors to track the cause of problems. Get back to smooth operation quickly with data back-ups.



Remotely analyze and optimize drives

Get critical drive information anywhere anytime – even in difficult to access sites, or when a site visit is impossible.

Connectivity devices enabling remote condition monitoring of drives

NETA-21

NETA-21 connects the drive to the cloud via the Internet or local Ethernet network.

- Up to nine drives can be connected to one module
- The module comes with a built-in web server and requires no Flash/Java plug-ins
- In the absence of a customer local area network, it can be connected via a mobile network router (either Ethernet or USB network adapter)
- The RMDE module with IP54 enclosure is available for already installed drives. It can contain two or four NETA 21 modules to connect up to 36 drives.



Connectivity Panel^{*)}

Connectivity Panel offers easy plug & play installation and commissioning with built-in connectivity.

- Built-in NB-IoT wireless module with strong signal penetration even if drive is underground or in cabinet
- High efficiency antenna for reliable connection
- Industrial SIM for best reliability including mobile data plan^{*)}
- Bluetooth® enables use of Mobile apps and PC tools



^{*)} Not available in all countries and for all drives. Please check availability of panel and services with your local ABB representative.

Customers can configure powertrains and customize the digital service plan

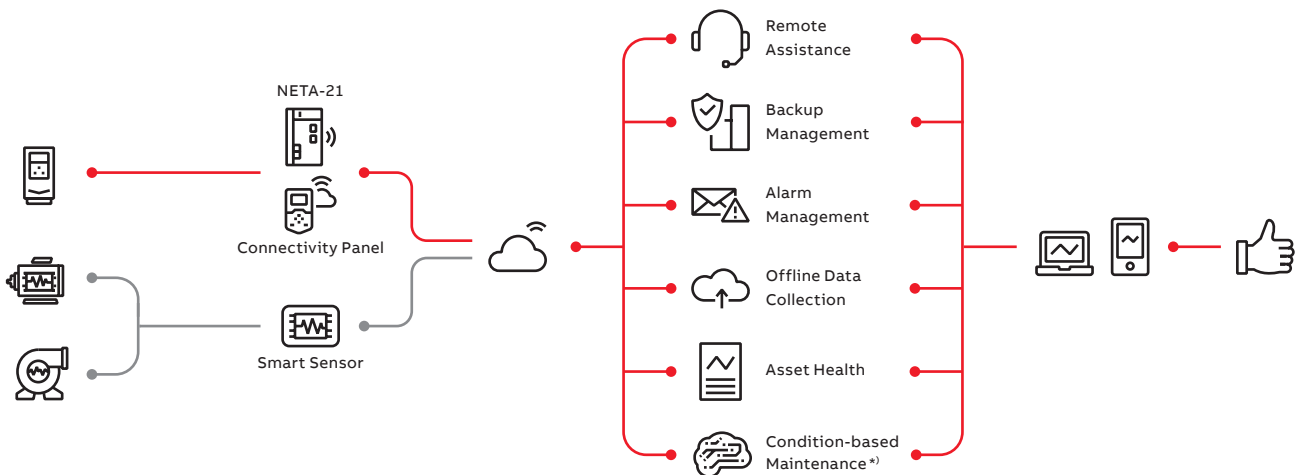

^{*)} Not available for all connectivity devices

EMC – electromagnetic compatibility

What is EMC?

EMC stands for electromagnetic compatibility. It is the ability of electrical/electronic equipment to operate without problems in an electromagnetic environment.

Likewise, the equipment must not disturb or interfere with any other product or system in its locality. This is a legal requirement for all equipment taken into service within the European Economic Area (EEA).

Installation environments

A power drive system (PDS) can be connected to either industrial or public power distribution networks. The environment class depends on the way the PDS is connected to power supply.

The **1st environment** includes domestic premises. It also includes establishments directly connected without an intermediate transformer to a low voltage power supply network that supplies buildings used for domestic purposes.

The **2nd environment** includes all establishments directly connected to public low voltage power supply networks.

EMC solutions

To fulfill the EMC requirements, the drives are equipped with standard or optional RFI filtering for HF disturbances.

- Using ferrite rings in power connection points
- Using an AC or DC choke (while they are meant to protect against harmonics, they reduce HF disturbances as well)
- Using an LCL filter in the case of regenerative drives
- Using a du/dt filter

Immunity and emission compatibility

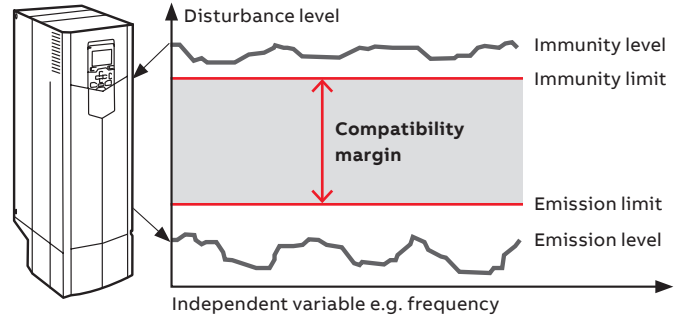

Installation environments

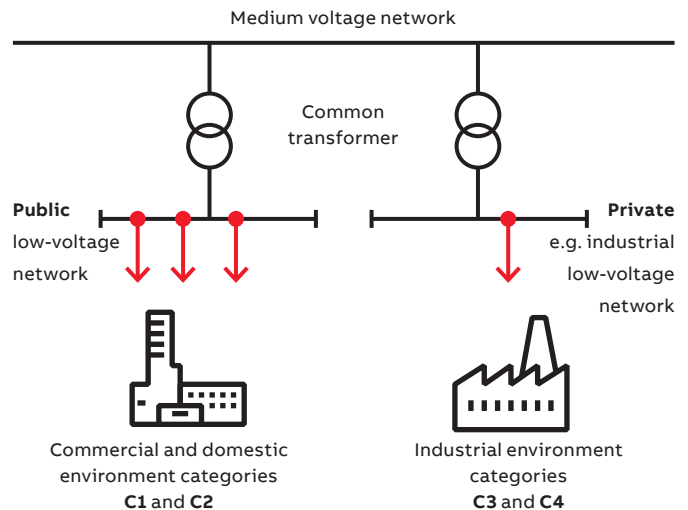

The product standard EN 61800-3 divides PDSs into four categories according to the intended use

C1 – 1st environment

- Household appliances
- Usually plug connectible to any wall outlet
- Anyone can connect these to the network
- Examples: washing machines, TV sets, computers, microwave ovens, etc.

C2 – 1st environment

- Fixed household and public appliances
- Need to be installed or operated by a professional
- Examples: elevators, rooftop fans, residential booster pumps, gates and barriers, supermarket freezers, etc.

C3 – 2nd environment

- Professional equipment
- Needs to be installed or operated by a professional
- In some rare cases, may also be pluggable
- Examples: any equipment for industrial usage only, such as conveyors, mixers, etc.

C4 – 2nd environment

- Professional equipment
- Needs to be fixed installation and operated by a professional
- Examples: paper machines, rolling mills, etc.



Every ACS580 drive is equipped with a built-in filter to reduce high-frequency emissions.

EMC product standard (EN 61800-3) category C2 is fulfilled in wall-mounted drives and in cabinet-built drives up to frame size R9. Category C3 is fulfilled in drive modules and cabinet-built drives (frames R10 and R11) with no external filters.

Comparison of EMC standards

EN 61800-3, product standard	EN 61800-3, product standard	EN 55011, product family standard for industrial, scientific and medical (ISM) equipment	EN 6100-6-4, generic emission standard for industrial environments	EN 61000-6-3, generic emission standard for residential, commercial and light-industrial environments
Category C1	1 st environment, unrestricted distribution	Group 1. Class B	Not applicable	Applicable
Category C2	1 st environment, restricted distribution	Group 1. Class A	Applicable	Not applicable
Category C3	2 nd environment, unrestricted distribution	Group 2. Class A	Not applicable	Not applicable
Category C4	2 nd environment, restricted distribution	Not applicable	Not applicable	Not applicable

EMC compliance and maximum cable length of ACS580-01/07 units *)

Type	Voltage	Frame sizes	1 st environment, restricted distribution, C1, grounded network (TN)	1 st environment, restricted distribution, C2, grounded network (TN)	2 nd environment, unrestricted distribution, C3, grounded network (TN)	2 nd environment, unrestricted distribution, C3, ungrounded network (IT)
ACS580-01	380-480 V	R1-R5	With the plus codes: +F316, +E223	Standard device, cable length 100 m	Standard device, cable length 100 m	–
ACS580-01/07	380-480 V	R6-R9	–	Standard device, cable length 150 m	Standard device, cable length 150 m	–
ACS580-04/07	380-480 V	R10-R11	–	–	Standard device, cable length 100 m	–

*) Motor cable operational functionality up to 300 m. See ACS580 hardware manuals 3AXD50000018826, 3AXD50000015497, 3AXD50000045815 and 3AXD50000032622 for frame specific information.

Harmonic mitigation

What are harmonics?

Harmonic currents are created by non-linear loads connected to the power distribution system. Harmonic distortion is a form of pollution in the electric plant that can cause problems if the voltage distribution caused by harmonic currents increases above certain limits.

All power electronic converters used in different types of electronic systems can increase harmonic disturbances by injecting harmonic currents directly into the grid.

Electricity supply is hardly ever a pure sine wave voltage, and current that deviates from the sine form contains harmonics. The distortion is caused by non-linear loads connected to the electrical supply. Harmonics cause disturbances and equipment failures.

The total current as the sum of the fundamental and 5th harmonics

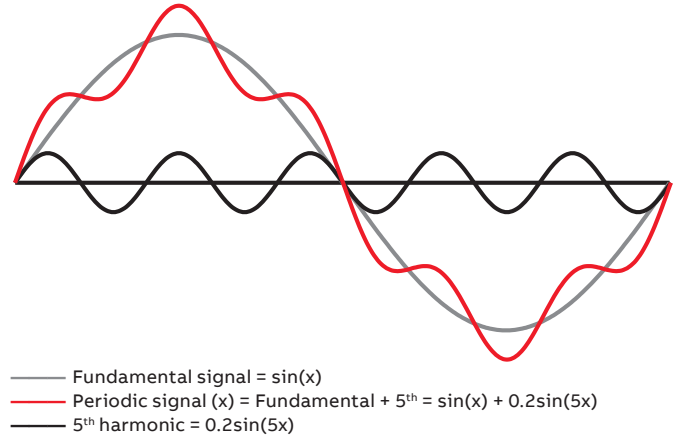

Where do the harmonics come from?

Non-linear loads such as:

- Variable speed drives
- Uninterrupted power supplies (UPS)
- Industrial rectifiers
- Welding machines
- Fluorescent lighting systems (electronic ballast)
- Computers
- Printers
- Servers
- Electronic appliances

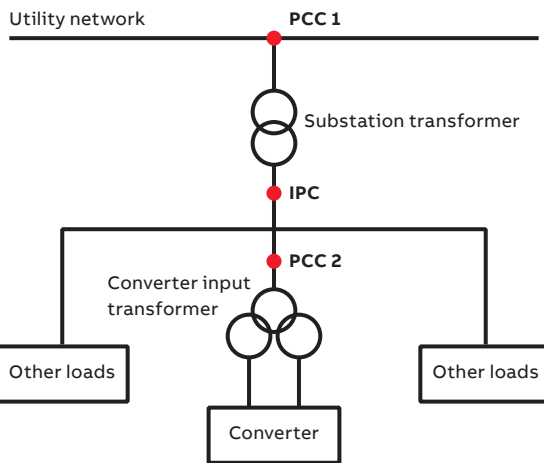

- Point of common coupling (**PCC**) is the point where the harmonic distortion is specified, e.g.
 - between the plant and the utility network (**PCC1**)
 - between the non-linear load and other loads within an industrial plant (**PCC 2**)

- In-plant point of coupling (**IPC**) is the point inside the customer system or installation to be studied

The effects of harmonic distortions

Harmonic currents

- Mainly affect the power distribution system up to the rectifier:
- Additional losses in wires and cables
 - Extra heating of transformers
 - Circuit breaker malfunctioning

Harmonic voltage

- Can affect other equipment connected to the electrical system:
- Erratic operation of telecommunication systems, computers, video monitors, electronic test equipment, etc.
 - Resonance with power factor correction capacitors

ACS580 drives are compliant with EN 61000-3-12. They are equipped with:

- optimized DC choke (R1-R9)
- AC chokes (R10-R11)

By choosing the ACS580, you can automatically make your plant more reliable. Built-in chokes mitigate harmonics reducing disturbances and equipment failures. Smaller harmonic content also saves money and makes the installation easier because it allows smaller fuses and longer motor cables to be used. Less harmonics also means longer lifetime for the components and thus less maintenance needs and downtime.



Reliable operation



Reduced cost



Longer lifetime

Drive system features affecting harmonics

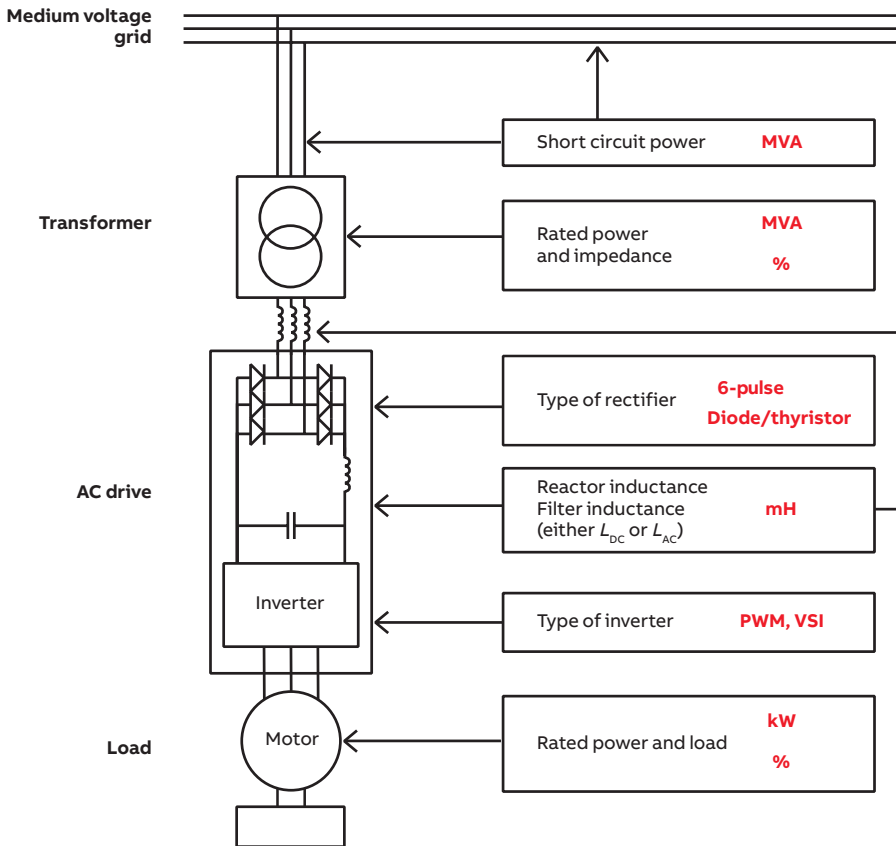

Harmonics reduction can be achieved either by structural modifications in the drive system or by using external filtering. The structural modifications may be to strengthen the supply, or to use 12 or more pulse drives, to use a controlled rectifier, or to improve the internal filtering in the drive.

The image to the left shows the factors in the AC drive system that have some influence on harmonics. The current harmonics depend on the drive construction, and the voltage harmonics are the current harmonics multiplied by the supply impedances.

For explosive atmospheres

ATEX certified

What is a potentially explosive atmosphere and where can it be?

Explosive atmospheres occur when flammable gases, mist, vapors or dust are mixed with air, which creates a risk of explosion. A potentially explosive area is defined as a location where there is a risk of flammable mixes. These atmospheres can be found throughout industries, from **chemical, pharmaceutical and food**, to **power and wood processing**. The electrical equipment that is installed in such locations must be designed and tested to endure these conditions and guarantee a safe function.



ATEX
 ATmosphères
 EXplosibles

What does ATEX mean?

The term ATEX comes from the French words "ATmosphères EXplosibles", and it is a combination of two EU directives: the Worker Protection Directive 1999/92/EC and the Product Directive 2014/34/ EU.

The ATEX Directives are designed to protect employees, the public and the environment from accidents owing to explosive atmospheres.

ATEX provides similar guidelines to the IECEx System, with a few exceptions, and with certification of protective devices (e.g. drive-integrated safety functions).



How to ensure safe operation?

With ABB's ATEX-certified offering and services, safe operation can be ensured.

Motors are directly connected to the machines in the potentially explosive atmosphere, and certain issues need to be considered when selecting a motor together with a drive. These atmospheres have a defined zone classification, and the zone defines the minimum requirements (category) the motors must comply with. The category defines the permitted motor protection types.

Potentially explosive atmosphere zones

Within industries, all potentially explosive atmospheres are required to have an area classification called Zones. Globally, a Zone system is used to classify potentially explosive areas. The Worker Protection Directive 1999/92/EC and the EU standards IEC 60079-10-x, EN 60079-10-x define these zones. In all cases, the owner of the site where the potentially explosive atmosphere exists has the responsibility to define the zones according to the requirements.

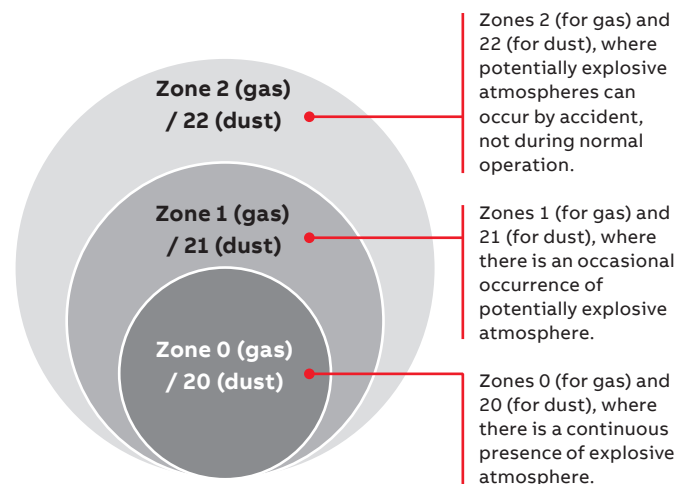

Tested packages



Motor and drive combinations are **tested and certified in ABB's test center**. By using an ABB motor together with an ABB drive as a package, you can enjoy the benefits of efficient, high-performance motors with optimal speed and control accuracy – without compromising on safety.

With the ABB ATEX certified motor and drive package the ATEX certified temperature protection modules are not obligatory, the tested combinations fulfill the IEC/ATEX standards and ensure safe performance.

- No additional testing and certification are needed
- No ATEX thermistor protection modules are needed
- Safe and cost effective solution for industries in potentially explosive atmospheres

Safe temperature monitoring



For non-tested and certified motors and drives (e.g. for use with other manufacturer's motors), ATEX certified temperature protection is an integrated option.

The ACS580's ATEX-certified thermistor protection module, Ex II (2) GD, CPTC-02, can be integrated into the drive if the motor is operating in a potentially explosive environment. **The purpose of the safety function is to disconnect the motor from the power supply before the motor overheats and causes a risk of explosion in an ATEX environment.**

Correct dimensioning

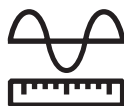

Correct dimensioning is important. **Correctly sized motors and drives reduce motor frame heating and sparks from bearing currents.** They also help to reduce energy use.

Insulation and drive filters



ABB's offering for correct insulation and filters **protects the motor** from voltage phenomena, bearing currents and motor overheating. The insulation and filters must be selected according to voltage and frame size.

Easy drive upgrades



With the drive upgrades below, the ATEX certification stays valid from the old to the new generation models. This means that there is no need for new ATEX certification during the upgrade. This saves you time and money.

ATEX certification approved – old generation model	Comparable converter upgrade	ATEX certification stays valid – new generation model
ACS550	→	ACS580

Global service and support network



ABB's global network of certified service providers are trained and experienced to help you with motors and drives for applications in explosive atmospheres.

The support network ensures that your ABB Declaration of Conformity is retained.

ABB's ATEX-certified thermistor protection module, Ex II (2) GD, CPTC-02

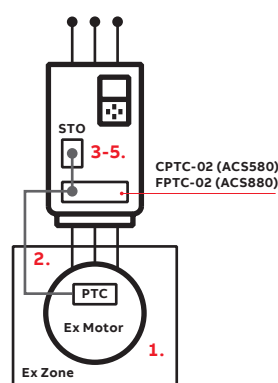

With option +L537 +Q971:

1. Motor temperature rises above the PTC sensor limit temperature.
2. The sensor resistance increases very sharply and indicates overheating to the ATEX-certified module, Ex II (2) GD.
3. The module switches the STO (Safe Torque Off) circuit off, which activates the STO function.
4. The STO function disables the control voltage in the power semiconductors of the drive output stage.
5. The drive is prevented from generating the required torque to rotate the motor.

► **The safe state is guaranteed**

Note:

The CPTC-02 module can be managed as a loose option and can also be retrofitted to the drive; in this case, to be compliant with regulations, the customer must ensure the following requirements:

- that the serial number of the drive/inverter module starts with 1, 4, 7, 8 or Y
- that the drive and option serial number is paired in a DIB (Drive Installed Base) portal
- that the included ATEX label for the SMT (Safe Motor Temperature) function is attached to the drive/inverter module to ensure the ATEX compliance of the safety circuit
- that the option module is installed in an option slot of the drive control unit and the applicable drive parameters are set
- that the PTC temperature sensors of the motor are connected to the PTC inputs of the option module.

* For further information please contact local ABB

ABB's ATEX-certified thermistor protection module

Option code	Ordering code	
+L537	3AXD50000033578	CPTC-02 ATEX-certified PTC interface, Ex II (2) GD and external 24 V (requires also option +Q971)
+Q971	-	ATEX-certified Safe Disconnection Function, Ex II (2) GD

Cooling and fuses

Cooling

ACS580 drives are fitted with variable-speed cooling air fans. The cooling air must be free from corrosive materials and not exceed the maximum ambient temperature of 40 °C for frames R1 to R9 (50 °C with derating). The speed-controlled fans cool the drive only when needed, which reduces overall noise level and energy consumption.

Fuse connections

Standard fuses can be used with ABB general purpose drives. For input fuses, see the table below.

Wall-mounted drives, ACS580-01

Cooling air flow and recommended input protection fuses for 380 to 480 V units

Type designation	Frame size	Cooling air flow 380 to 480 V units				Recommended input protection fuses for 380 to 480 V units***)			
		Typical heat dissipation*)	Air flow		Max. noise level**)	IEC fuses		UL fuses	
			(W)	(m ³ /h)		(ft ³ /min)	(dBA)	(A)	Fuse type
ACS580-01-02A7-4	R1	42	43	25	55	4	gG	15	UL Class T
ACS580-01-03A4-4	R1	50	43	25	55	6	gG	15	UL Class T
ACS580-01-04A1-4	R1	59	43	25	55	6	gG	15	UL Class T
ACS580-01-05A7-4	R1	83	43	25	55	10	gG	15	UL Class T
ACS580-01-07A3-4	R1	97	43	25	55	10	gG	15	UL Class T
ACS580-01-09A5-4	R1	135	43	25	55	16	gG	15	UL Class T
ACS580-01-12A7-4	R1	211	43	25	55	16	gG	15	UL Class T
ACS580-01-018A-4	R2	238	101	59	66	25	gG	30	UL Class T
ACS580-01-026A-4	R2	381	101	59	66	32	gG	30	UL Class T
ACS580-01-033A-4	R3	492	179	105	76	40	gG	40	UL Class T
ACS580-01-039A-4	R3	525	179	105	76	50	gG	60	UL Class T
ACS580-01-046A-4	R3	677	179	105	76	63	gG	60	UL Class T
ACS580-01-062A-4	R4	867	134	79	69	80	gG	80	UL Class T
ACS580-01-073A-4	R4	1114	134	79	69	100	gG	90	UL Class T
ACS580-01-089A-4	R4	1059	159	94	70	100	gG	110	UL Class T
ACS580-01-088A-4	R5	1139	139	82	63	100	gG	110	UL Class T
ACS580-01-106A-4	R5	1290	139	82	63	125	gG	150	UL Class T
ACS580-01-145A-4	R6	1960	435	256	67	160	gG	200	UL Class T
ACS580-01-169A-4	R7	2021	450	265	67	250	gG	225	UL Class T
ACS580-01-206A-4	R7	2785	450	265	67	315	gG	300	UL Class T
ACS580-01-246A-4	R8	3126	550	324	65	355	gG	350	UL Class T
ACS580-01-293A-4	R8	4066	550	324	65	425	gG	400	UL Class T
ACS580-01-363A-4	R9	4834	1150	677	68	500	gG	500	UL Class T
ACS580-01-430A-4	R9	6067	1150	677	68	630	gG	600	UL Class T

*) Heat dissipation value is a reference for cabinet thermal design. According to Ecodesign regulations.

**) The maximum noise level at full fan speed. When the drive is not operating at full load and at maximum ambient temperature the noise level is lower.

***) For detailed fuse sizes and types, please see the ACS580 HW manuals, document codes: 3AXD50000018826 and 3AXD50000015497.

Note: For flange mounting, please refer to the ACS580 HW manuals, document codes: 3AXD50000018826 and 3AXD50000015497.

Wall-mounted drives, ACS580-01 230 V

Cooling air flow and recommended input protection fuses for 200 to 240 V units

Type designation	Frame size	Cooling air flow 200 to 240 V units				Recommended input protection fuses for 200 to 240 V units	
		Typical heat dissipation *)	Air flow		Max. noise level **)	IEC fuses	
			(W)	(m³/h)		(ft³/min)	(A)
ACS580-01-04A7-2	R1	51	43	25	59	25	gG
ACS580-01-06A7-2	R1	70	43	25	59	25	gG
ACS580-01-07A6-2	R1	80	43	25	59	25	gG
ACS580-01-012A-2	R1	142	43	25	59	25	gG
ACS580-01-018A-2	R1	228	43	25	59	25	gG
ACS580-01-025A-2	R2	253	101	59	64	40	gG
ACS580-01-032A-2	R2	358	101	59	64	40	gG
ACS580-01-047A-2	R3	527	179	105	76	63	gG
ACS580-01-060A-2	R3	775	179	105	76	63	gG
ACS580-01-089A-2	R5	876	139	82	63	125	gG
ACS580-01-115A-2	R5	1285	139	82	63	125	gG
ACS580-01-144A-2	R6	1932	435	256	67	200	gG
ACS580-01-171A-2	R7	2000	450	265	67	250	gG
ACS580-01-213A-2	R7	2854	450	265	67	315	gG
ACS580-01-276A-2	R8	3567	550	324	65	400	gG

*) Heat dissipation value is a reference for cabinet thermal design. According to Ecodesign regulations.

**) The maximum noise level at full fan speed. When the drive is not operating at full load and at maximum ambient temperature the noise level is lower.

Drive modules, ACS580-04

Cooling air flow and recommended input protection fuses for 380 to 480 V units

Type designation	Frame size	Cooling air flow 380 to 480 V units				Recommended input protection fuses for 380 to 480 V units ***)			
		Typical heat dissipation *)	Air flow		Max. noise level **)	IEC fuses		UL fuses	
			(W)	(m³/h)		(ft³/min)	(dBA)	(A)	Fuse type
ACS580-04-505A-4	R10	6454	1200	707	72	***)	***)	***)	***)
ACS580-04-585A-4	R10	6828	1200	707	72	***)	***)	***)	***)
ACS580-04-650A-4	R10	8036	1200	707	72	***)	***)	***)	***)
ACS580-04-725A-4	R11	8095	1200	707	72	***)	***)	***)	***)
ACS580-04-820A-4	R11	9641	1200	707	72	***)	***)	***)	***)
ACS580-04-880A-4	R11	10874	1420	848	72	***)	***)	***)	***)

*) Heat dissipation value is a reference for cabinet thermal design. According to Ecodesign regulations.

**) The maximum noise level at full fan speed. When the drive is not operating at full load and at maximum ambient temperature the noise level is lower.

***) For detailed fuse sizes and types, please see the ACS580 HW manuals, document codes: 3AXD50000018826 and 3AXD50000015497.

Cabinet-built drives, ACS580-07

Cooling air flow and recommended input protection fuses for 380 to 480 V units

Type designation	Frame size	Cooling air flow 380 to 480 V units				Recommended input protection fuses for 380 to 480 V units ***)				
		Typical heat dissipation *)	Air flow		Max. noise level **)	IEC fuses		UL fuses		
			(W)	(BTU/Hr)		(m³/h)	(ft³/min)	(dBA)	(A)	Fuse type
ACS580-07-0145A-4	R6	2487	8485	685	403	67	250	170M3816D	250	DFJ-250
ACS580-07-0169A-4	R7	2497	8519	700	412	67	250	170M3816D	300	DFJ-300
ACS580-07-0206A-4	R7	3314	11307	700	412	67	315	170M3817D	300	DFJ-300
ACS580-07-0246A-4	R8	3806	12987	800	471	65	400	170M5408	400	170M5408
ACS580-07-0293A-4	R8	4942	16863	800	471	65	500	170M5410	500	170M5410
ACS580-07-0363A-4	R9	5868	20024	1400	824	68	630	170M6410	630	170M6410
ACS580-07-0430A-4	R9	7600	25932	1400	824	68	700	170M6411	700	170M6411
ACS580-07-0505A-4	R10	8353	28502	1900	1118	72	800	170M6412	***)	***)
ACS580-07-0585A-4	R10	9471	32317	1900	1118	72	900	170M6413	***)	***)
ACS580-07-0650A-4	R10	11200	38215	1900	1118	72	1000	170M6414	***)	***)
ACS580-07-0725A-4	R11	11386	38851	2400	1413	72	1250	170M6416	***)	***)
ACS580-07-0820A-4	R11	13725	46831	2400	1413	72	1250	170M6416	***)	***)
ACS580-07-0880A-4	R11	15300	52207	2620	1542	72	1400	170M6417	***)	***)

*) Heat dissipation value is a reference for cabinet thermal design. According to Ecodesign regulations.

**) The maximum noise level at full fan speed. When the drive is not operating at full load and at maximum ambient temperature the noise level is lower.

***) For detailed fuse sizes and types, please see the ACS580 HW manuals, document codes: 3AXD50000018826, 3AXD50000015497, 3AXD50000045815 and 3AXD50000032622.

Circuit breakers

ACS580-01								
Type designation ACS580-01-	Frame size	Aux. Contr. Volt.:	Miniature circuit breaker	T_{max} moulded case circuit breaker		Switch-disconnector		Main contactor (≤ 40 °C)
				ABB type	ABB type	Main Switch ABB type	Main Switch UL ABB type	
3-phase, $U_N = 400$ or 480 V (380...415 V. 440...480 V)								
02A7-4	R1	230/115	S 203P-B/C/Z 10	-	-	OT16F3	OT16F3	AF09-30-22-13
03A4-4	R1	230/115	S 203P-B/C/Z 10	-	-	OT16F3	OT16F3	AF09-30-22-13
04A1-4	R1	230/115	S 203P-B/C/Z 10	-	-	OT16F3	OT16F3	AF09-30-22-13
05A7-4	R1	230/115	S 203P-B/C/Z 10	-	-	OT16F3	OT16F3	AF09-30-22-13
07A3-4	R1	230/115	S 203P-B/C/Z 10	-	-	OT16F3	OT16F3	AF09-30-22-13
09A5-4	R1	230/115	S 203P-B/C/Z 10	-	-	OT16F3	OT16F3	AF09-30-22-13
12A7-4	R1	230/115	S 203P-B/C/Z 16	-	-	OT16F3	OT16F3	AF09-30-22-13
018A-4	R2	230/115	S 203P-B/C/Z 20	-	-	OT25F3	OT25F3	AF09-30-22-13
026A-4	R2	230/115	S 203P-B/C/Z 25	-	-	OT25F3	OT25F3	AF12-30-22-13
033A-4	R3	230/115	S 203P-B/C/Z 32	-	-	OT63F3	OT63F3	AF26-30-22-13
039A-4	R3	230/115	S 203P-B/C/Z 40	-	-	OT63F3	OT63F3	AF52-30-22-13
046A-4	R3	230/115	S 203P-B/C/Z 50	-	-	OT63F3	OT63F3	AF52-30-22-13
062A-4	R4	230/115	S 803 S-B/C 75	-	-	OT100F	OT100F	AF52-30-22-13
073A-4	R4	230/115	-	1SDA067918R1	Prospective SC current 65kA	OT100F	OT100F	AF52-30-22-13
089A-4	R4	230/115	-	1SDA067918R1	Prospective SC current 65kA	OT160EV	OT200U	AF65-30-22-13
088A-4	R5	230/115	-	1SDA067918R1	Prospective SC current 65kA	OT160EV	OT200U	AF65-30-22-13
106A-4	R5	230/115	-	1SDA068555R1	Prospective SC current 65kA	OT160EV	OT200U	AF146-30-22-13
145A-4	R6	230/115	-	1SDA068555R1	Prospective SC current 65kA	OT160EV	OT200U	AF146-30-22-13
169A-4	R7	230/115	-	1SDA068555R1	Prospective SC current 65kA	OT250E	OT400U	AF146-30-22-13
206A-4	R7	230/115	-	1SDA054141R1	Prospective SC current 65kA	OT250E	OT400U	AF146-30-22-13
246A-4	R8	230/115	-	1SDA054365R1	Prospective SC current 65kA	OT400E	OT400U	AF265-30-22-13
293A-4	R8	230/115	-	1SDA054420R1	Prospective SC current 65kA	OT400E	OT400U	AF265-30-22-13
363A-4	R9	230/115	-	1SDA054420R1	Prospective SC current 65kA	OT630E	OT600U	AF400-30-22-70
430A-4	R9	230/115	-	1SDA054420R1	Prospective SC current 65kA	OT630E	OT600U	AF400-30-22-70

ACS580-04								
Type designation ACS580-04-	Frame size	Aux. Contr. Volt.:	Miniature circuit breaker	T_{max} moulded case circuit breaker		Switch-disconnector		Main contactor (≤ 40 °C)
				ABB type	ABB type	Main Switch ABB type	Main Switch UL ABB type	
$U_N = 380...480$ V (380, 400, 415 V)								
505A-4	R10	230/115	-	1SDA054412R1	(T5H 630 PR221DS-LS/I $I_n = 630$ 3p F F)	OT630E	OT600U	-
585A-4	R10	230/115	-	1SDA069428R1	(T6V 800 PR221DS-LS/I $I_n = 800$ 3p F F)	OT630E	OT600U	-
650A-4	R10	230/115	-	1SDA069428R1	(T6V 800 PR221DS-LS/I $I_n = 800$ 3p F F)	OT800E	OT800U	-
725A-4	R11	230/115	-	1SDA062770R1	(T7H 1000 PR231/P LS/I $I_n = 1000A$ 3p F F)	OT800E	OT800U	-
820A-4	R11	230/115	-	1SDA062770R1	(T7H 1000 PR231/P LS/I $I_n = 1000A$ 3p F F)	OT1000E	OT1200U	-
880A-4	R11	230/115	-	1SDA062770R1	(T7H 1000 PR231/P LS/I $I_n = 1000A$ 3p F F)	OT1000E	OT1200U	-



External du/dt filter for ACS580-01		du/dt filter type												
		Unprotected (IP00)					Protected to IP22			Protected to IP54				
ACS580 220 to 240 V		NOCH0016-60	NOCH0030-60	FOCH0320-50	FOCH0610-70	FOCH0875-70	NOCH0016-62	NOCH0030-62	NOCH0070-62	NOCH0120-62	NOCH0016-65	NOCH0030-65	NOCH0120-65	BOCH-0880A-7
ACS580-01-04A7-2		•					•				•			
ACS580-01-06A7-2		•					•				•			
ACS580-01-07A6-2		•					•				•			
ACS580-01-012A-2		•					•				•			
ACS580-01-018A-2		•					•				•			
ACS580-01-025A-2			•					•				•		
ACS580-01-032A-2			•					•				•		
ACS580-01-047A-2				•					•				•	
ACS580-01-060A-2				•					•				•	
ACS580-01-089A-2				•					•				•	
ACS580-01-115A-2					•				•				•	
ACS580-01-144A-2						•								
ACS580-01-144A-2+B056						•								
ACS580-01-171A-2						•								
ACS580-01-171A-2+B056						•								
ACS580-01-213A-2						•								
ACS580-01-213A-2+B056						•								
ACS580-01-276A-2						•								
ACS580-01-276A-2+B056						•								

External du/dt filters for ACS580-07		du/dt filter type		
		Protected to IP54		
ACS580 400 V		BOCH-0880A-7	COF-01	COF-02
ACS580-07-0145A-4			•	
ACS580-07-0169A-4			•	
ACS580-07-0206A-4			•	
ACS580-07-0246A-4				•
ACS580-07-0293A-4				•
ACS580-07-0363A-4				•
ACS580-07-0430A-4				•
ACS580-07-0505A-4		•		
ACS580-07-0585A-4		•		
ACS580-07-0650A-4		•		
ACS580-07-0725A-4		•		
ACS580-07-0820A-4		•		
ACS580-07-0880A-4		•		

Dimensions and weights of the du/dt filters

du/dt filter	Height	Width	Depth	Weight
^{*)} 3 filters included, dimensions apply to one filter.	(mm)	(mm)	(mm)	(kg)
NOCH0016-60	195	140	115	2.4
NOCH0016-62/65	323	199	154	6
NOCH0030-60	215	165	130	4.7
NOCH0030-62/65	348	249	172	9
NOCH0070-60	261	180	150	9.5
NOCH0070-62/65	433	279	202	15.5
NOCH0120-60 ^{*)}	200	154	106	7
NOCH0120-62/65	765	308	256	45
FOCH0260-70	382	340	254	47
FOCH0320-50	662	319	293	65
FOCH0610-70	662	319	293	65
FOCH0875-70	662	319	293	65
BOCH-0880A-7	400	248	456	18
COF-01	570	296	360	23
COF-02	570	360	301	23

Sine filters

Sine filters are low-pass filters that suppress the high frequency components of the drive output.

A sine filter consists of single- or three-phase reactors and delta- or star-connected capacitors. The sine filter provides true sinusoidal voltage waveform at the drive output by suppressing the high frequency voltage components of the drive output. Suppression of the high frequency voltage components is needed when extra-long motor cables are used, there is a step-up transformer between the drive and a motor, or when a drive is installed with an old direct-on-line motor.

ACS580-01, sine filters			
Type designation	Type code Sine filter IP00	Type code Housing case IP21 *)	$I_{cont. max}$ (A)
3-phase, $U_N = 380...480$ V. The power ratings are valid at nominal voltage 400 V (0.75 to 250 kW).			
ACS580-01-02A7-4	B84143V0004R229	B84143Q0002R229	2.3
ACS580-01-03A4-4	B84143V0004R229	B84143Q0002R229	3.1
ACS580-01-04A1-4	B84143V0004R229	B84143Q0002R229	3.8
ACS580-01-05A7-4	B84143V0006R229	B84143Q0002R229	5.3
ACS580-01-07A3-4	B84143V0011R229	B84143Q0004R229	6.9
ACS580-01-09A5-4	B84143V0011R229	B84143Q0004R229	9.2
ACS580-01-12A7-4	B84143V0016R229	B84143Q0006R229	12.1
ACS580-01-018A-4	B84143V0016R229	B84143Q0006R229	16
ACS580-01-026A-4	B84143V0025R229	B84143Q0008R229	24
ACS580-01-033A-4	B84143V0033R229	B84143Q0008R229	31
ACS580-01-039A-4	B84143V0050R229	B84143Q0010R229	37
ACS580-01-046A-4	B84143V0050R229	B84143Q0010R229	43
ACS580-01-062A-4	B84143V0066R229	B84143Q0010R229	58
ACS580-01-073A-4	B84143V0066R229	B84143Q0010R229	64
ACS580-01-089A-4	B84143V0095R229	B84143Q0012R229	77
ACS580-01-088A-4	B84143V0095R229	B84143Q0012R229	77
ACS580-01-106A-4	B84143V0095R229	B84143Q0012R229	91
ACS580-01-145A-4	B84143V0162S229	B84143Q0014R229	126
ACS580-01-169A-4	B84143V0162S229	B84143Q0014R229	153
ACS580-01-206A-4	B84143V0230S229	B84143Q0016R229	187
ACS580-01-246A-4	B84143V0230S229	B84143Q0016R229	209
ACS580-01-293A-4	B84143V0390S229	B84143Q0018R229	249
ACS580-01-363A-4	B84143V0390S229	B84143Q0018R229	297
ACS580-01-430A-4	B84143V0390S229	B84143Q0018R229	352

*) If a sinus filter IP21 is needed please order both type codes for Housing case IP21 and Sine filter IP00.

Example: if a IP21 sine filter is needed for an ACS580-01-02A7-4 it is necessary to order both B84143V0004R229 and B84143Q0002R229.

ACS580 drives are compatible with the wide ABB product offering



Programmable Logic Controllers PLCs

The AC500, AC500-eCo, AC500-S and AC500-XC scalable PLC ranges provide solutions for small, medium and high-end applications. Our AC500 PLC platform offers different performance levels and is the ideal choice for high availability, extreme environments, condition monitoring, motion control or safety solutions.



AC motors

ABB's low voltage AC motors are designed to save energy, reduce operating costs and minimize unscheduled downtime. General performance motors ensure convenience, while process performance motors provide a broad set of motors for the process industries and heavy-duty applications.



Control panels

CP600-eCo, CP600 and CP600-Pro control panels offer a wide range of features and functionalities for maximum operability. ABB control panels are distinguished by their robustness and easy usability, providing all the relevant information from production plants and machines at a single touch.



All-compatible drives portfolio

The all-compatible drives share the same architecture; software platform, tools, user interfaces and options. Yet, there is an optimal drive from the smallest water pump to the biggest cement kiln, and everything in between.



Safety products

ABB safety products are helping machine builders to create production-friendly and safe work environments for operators. We deliver machine safety solutions for single machines or entire production lines. Our long experience of helping customers making solutions for demanding environments has made us experts in combining production demands with safety demands for production-friendly solutions.

Choose the right motor for your application

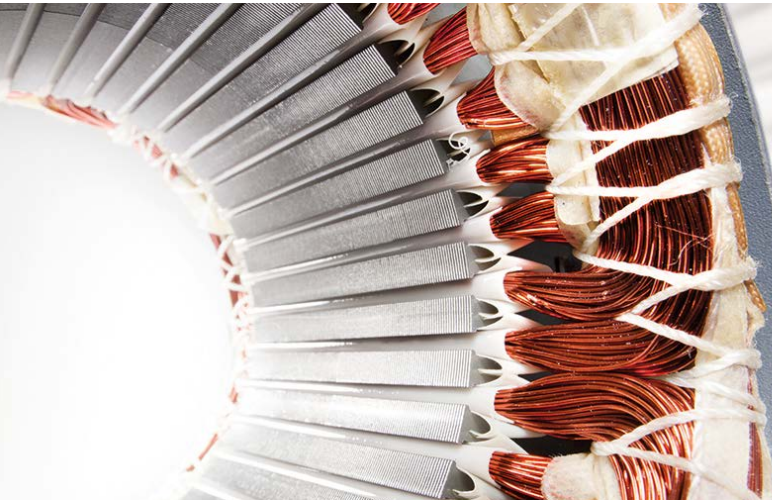

Choose the best motor for your application. A natural match for induction motors, ABB general purpose drives can also control high-efficiency motors such as permanent magnet or synchronous reluctance motors for greater efficiency.

Induction motors, the industry workhorse

Pair the ACS480 or ACS580 with an induction motor (IM) for simple and reliable operation in many applications and in a wide range of environments. Further simplifying setup, the general purpose drives can be integrated with virtually any type of IM by entering the nameplate motor data only.



Permanent magnet motors for smooth operation

Permanent magnet technology is used for improved motor characteristics in terms of energy efficiency and compactness. This technology is particularly well-suited for low speed control applications, as they eliminate the need to use gear boxes. Even without speed or rotor position sensors, the ACS480 or ACS580 drives control most types of permanent magnet motors.

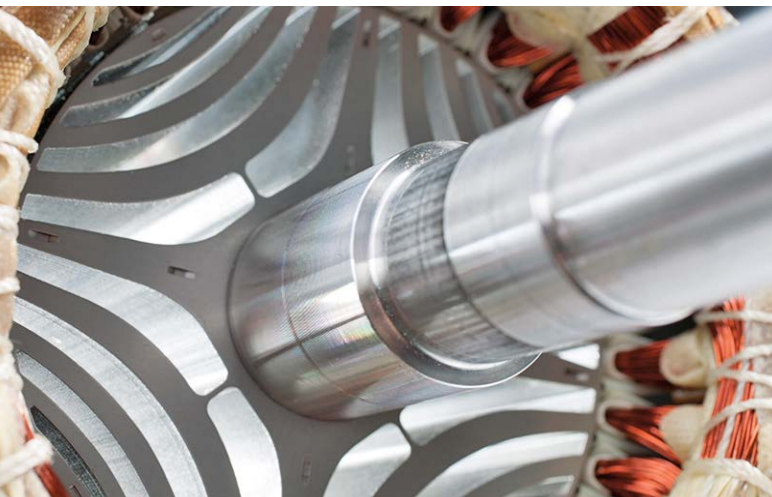

IE5 SynRM for optimized energy efficiency

Combining ABB's general purpose drive control technology with our synchronous reluctance motors will give you a motor and a drive package that ensures high energy efficiency, reduces motor temperatures, and provides a significant reduction in motor noise. The key is in the efficiency-optimized rotor design of our SynRM motors.

Synchronous reluctance motors

Ultimate efficiency and reliability to optimize your cost of ownership



Traditional induction motor



IE5 SynRM motor

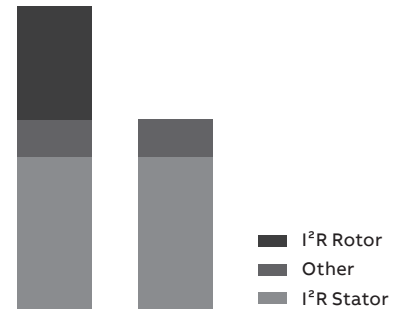

Losses IM vs SynRM

Innovation inside

The idea is simple. Take a conventional, proven stator technology and an innovative rotor design. Then combine them with an ABB general purpose drive loaded with software with versatile features. Finally, optimize the whole package for applications such as compressors, conveyors, mixers, pumps, centrifuges, fans and many other variable and constant torque applications.

Magnet-free design

Synchronous reluctance technology combines the performance of a permanent magnet motor with the simplicity and service-friendliness of an induction motor. The new rotor has neither magnets nor windings, and suffers virtually no power losses. And because there are no magnetic forces in the rotor, maintenance is as straightforward as with induction motors.

Superior reliability to minimize the cost of not running

International Efficiency class IE5 synchronous reluctance motors (SynRM) have very low winding temperatures, which increases the reliability and lifetime of the winding. More importantly, a cool synchronous reluctance rotor means significantly lower bearing temperatures – an important factor because bearing failures cause about 70 percent of unplanned motor outages.

Perfect for retrofits

The SynRM package is a perfect solution for motor retrofits. The IE5 SynRM is the same size as an IE3 induction motor, eliminating the need for mechanical modifications. The increased efficiency will, on the other hand, reduce the payback time of the investment.

Full motor control, down to zero speed

Many processes require accurate speed control. SynRM always runs at reference speed with practically no error, without an encoder. Even the best slip compensation systems in an induction motor inverter will never match the precision of SynRM. Sometimes your application may require you to run your motor at slow speeds. If you are using SynRM and your drive cannot provide the necessary torque, it may trip. ABB drives provide full control and torque down to zero speed, even without speed sensors.

For all applications

This is important if you are planning on using the motor with applications other than quadratic torque applications like pumps and fans. Our drives provide full SynRM motor control for constant torque applications such as extruders, conveyors and wire drawing machines.

SynRM technology	Benefit
Higher efficiency IE5	Lowest energy consumption
No rare earth metals	Environmental sustainability
Magnet-free rotor	Easy service
Lower winding and bearing temperatures	Longer life time, extended service intervals
Better controllability	Accurate speed and torque control
Lower noise level	Better working and living environment
Same size with IE3	Perfect for retrofits



Selection guide

IE5 synchronous reluctance motors

This table presents performance data for IE5 SynRM motor and ACS580 drive package.
Variant codes and construction details are based on the M3BP motor, protection IP55, cooling IC 411,
insulation class F, temperature rise class B.

Output (kW)	Motor type ^{*)}	Product code	Motor efficiency (%)	Motor nominal current (A)	Motor nominal torque (Nm)	Motor weight (kg)	Matched ACS580-01 drive	Package efficiency ^{**)} IES at nominal point (Pn) (%)	PDS ^{***)} IES2 efficiency class low limit (%)	Package efficiency above IES2 efficiency class low limit (%)	Drive frame size
3000 RPM / 100 Hz						400 V network					
5.5	M3AL132SMA4	3GAL132217-C	92.8	12.1	17.5	41	ACS580-01-12A7-4	89.6	82.5	8.6	R1
7.5	M3AL132SMB4	3GAL132227-C	93.1	16.5	23.9	41	ACS580-01-018A-4	90.4	83.9	7.7	R2
11	M3AL132SMC4	3GAL132237-C	94	24.5	35	47	ACS580-01-026A-4	90.9	85.3	6.6	R2
11	M3BL160MLA4	3GBL162417-C	93.6	25.6	35	133	ACS580-01-033A-4	90.4	85.3	6.0	R3
15	M3AL132SMD4	3GAL132247-C	94.1	32.9	47.8	47	ACS580-01-039A-4	91.2	86.2	5.8	R3
15	M3BL160MLB4	3GBL162427-C	95.1	34.6	48	133	ACS580-01-039A-4	92.2	86.2	7.0	R3
18.5	M3BL160MLC4	3GBL162437-C	94.6	43.3	59	133	ACS580-01-046A-4	91.3	86.9	5.1	R3
22	M3BL180MLB4	3GBL182427-C	95.5	50.5	70	190	ACS580-01-062A-4	92.5	87.3	6.0	R4
30	M3BL200MLC4	3GBL202437-C	95.9	68.9	95.6	277	ACS580-01-073A-4	92.5	88.1	5.0	R4
37	M3BL200MLD4	3GBL202447-C	96.1	84.5	118	277	ACS580-01-089A-4	93.5	88.6	5.5	R4
45	M3BL225SMB4	3GBL22227-C	96.1	99.8	143	330	ACS580-01-106A-4	93.5	89	5.1	R5
55	M3BL250SMA4	3GBL252217-C	96.4	123	175	396	ACS580-01-145A-4	93.6	89.4	4.7	R6
75	M3BL250SMB4	3GBL25227-C	96.5	167	239	396	ACS580-01-169A-4	93.8	90	4.2	R7
90	M3BL250SMC4	3GBL252237-C	96.4	198	286	454	ACS580-01-206A-4	93.4	90.2	3.5	R7
1500 RPM / 50 Hz											
5.5	M3AL132SMA4	3GAL132213-C	93.7	11.7	35	63	ACS580-01-12A7-4	90.4	82.5	9.6	R1
7.5	M3AL132SMB4	3GAL132223-C	93.7	15.7	47.8	63	ACS580-01-018A-4	91	83.9	8.5	R2
11	M3AL132SMC4	3GAL132233-C	94.2	23.8	70	69	ACS580-01-026A-4	90.9	85.3	6.6	R2
11	M3BL160MLA4	3GBL162413-C	94	24.2	70	160	ACS580-01-026A-4	90.8	85.3	6.4	R2
15	M3BL160MLB4	3GBL162423-C	94.9	31.3	95	177	ACS580-01-039A-4	91.9	86.2	6.6	R3
18.5	M3BL180MLB4	3GBL182423-C	95	42.8	118	222	ACS580-01-046A-4	91.4	86.9	5.2	R3
22	M3BL180MLC4	3GBL182433-C	95.4	49.4	140	222	ACS580-01-062A-4	92.1	87.3	5.5	R4
30	M3BL200MLB4	3GBL202423-C	95.9	65	191	304	ACS580-01-073A-4	92.5	88.1	5.0	R4
37	M3BL225SMB4	3GBL22223-C	96.3	79.3	236	385	ACS580-01-089A-4	93.8	88.6	5.9	R4
45	M3BL225SMC4	3GBL222233-C	96.3	98.5	286	350	ACS580-01-106A-4	93.5	89	5.1	R5
55	M3BL250SMB4	3GBL252223-C	96.5	117	350	454	ACS580-01-145A-4	93.5	89.4	4.6	R6
75	M3BL280SMA4	3GBL282213-C	96.2	166	478	639	ACS580-01-169A-4	93.6	90	4.0	R7
90	M3BL280SMB4	3GBL282223-C	96.5	199	573	639	ACS580-01-206A-4	93.5	90.2	3.7	R7
110	M3BL280SMC4	3GBL282233-C	96.7	241	699	697	ACS580-01-246A-4	93.9	90.5	3.8	R8
110	M3BL315SMA4	3GBL312213-C	96.8	243	702	873	ACS580-01-246A-4	94.1	90.5	4.0	R8
132	M3BL315SMB4	3GBL312223-C	96.8	290	842	925	ACS580-01-293A-4	93.8	90.7	3.4	R8
160	M3BL315SMC4	3GBL312233-C	97.1	343	1018	965	ACS580-01-363A-4	94.2	90.9	3.6	R9
200	M3BL315MLA4	3GBL312413-C	97.2	428	1272	1116	ACS580-01-430A-4	94.1	91.1	3.3	R9
250	M3BL315LKA4	3GBL312813-C	97.1	552	1591	1357	ACS580-04-585A-4	94.6	91.2	3.7	R10
315	M3BL315LKC4	3GBL312833-C	97.2	662	2006	1533	ACS580-04-725A-4	94.9	91.2	4.1	R11

^{*)} Motor type M3AL = aluminum motor frame
Motor type M3BL = cast iron motor frame

^{**)} Calculated package efficiency values for ACS580-01
^{***)} PDS = Power Drive System

Output (kW)	Motor type ^{*)}	Product code	Motor efficiency (%)	Motor nominal current (A)	Motor nominal torque (Nm)	Motor weight (kg)	Matched ACS580-01 drive	Package efficiency ^{**)} IES at nominal point (Pn) (%)	PDS ^{***)} IES2 efficiency class low limit (%)	Package efficiency above IES2 efficiency class low limit (%)	Drive frame size
1000 RPM / 33.3 Hz							400 V network				
7.5	M3BL160MLA4	3GBL162412-C	93.1	16.5	72	160	ACS580-01-018A-4	90.2	83.9	7.5	R2
11	M3BL160MLB4	3GBL162422-C	93.7	24.1	105	177	ACS580-01-026A-4	90.4	85.3	6.0	R2
15	M3BL180MLC4	3GBL182432-C	94.2	34.1	143	216	ACS580-01-039A-4	90.9	86.2	5.5	R3
18.5	M3BL200MLA4	3GBL202412-C	95.2	39.9	177	304	ACS580-01-046A-4	91.9	86.9	5.8	R3
22	M3BL200MLB4	3GBL202422-C	95	47	210	304	ACS580-01-062A-4	91.9	87.3	5.3	R4
30	M3BL225SMB4	3GBL222222-C	95.5	64.7	287	348	ACS580-01-073A-4	92.1	88.1	4.5	R4
37	M3BL250SMA4	3GBL252212-C	95.6	80.5	353	428	ACS580-01-089A-4	93.3	88.6	5.3	R4
45	M3BL280SMA4	3GBL282212-C	96.2	98.6	430	639	ACS580-01-106A-4	93.5	89	5.1	R5
55	M3BL280SMB4	3GBL282222-C	96	119	526	639	ACS580-01-145A-4	93	89.4	4.0	R6
75	M3BL280SMC4	3GBL282232-C	96.2	160	715	697	ACS580-01-169A-4	93.6	90	4.0	R7
75	M3BL315SMA4	3GBL312212-C	96.5	164	717	873	ACS580-01-169A-4	93.8	90	4.2	R7
90	M3BL315SMB4	3GBL312222-C	96.8	199	859	925	ACS580-01-206A-4	93.7	90.2	3.9	R7
110	M3BL315SMC4	3GBL312232-C	96.8	241	1051	965	ACS580-01-246A-4	93.9	90.5	3.8	R8
132	M3BL315MLA4	3GBL312412-C	97.1	278	1261	1116	ACS580-01-293A-4	94	90.7	3.6	R8
160	M3BL315LKA4	3GBL312812-C	97.1	341	1527	1357	ACS580-01-363A-4	94.2	90.9	3.6	R9
200	M3BL315LKC4	3GBL312832-C	97.3	416	1910	1533	ACS580-01-430A-4	94.3	91.1	3.5	R9

*) Motor type M3AL = aluminum motor frame
Motor type M3BL = cast iron motor frame

**) Calculated package efficiency values for ACS580-01
***) PDS = Power Drive System



ABB Access

Scan the QR code to access 24/7 self-services for ABB drives, motors and PLCs

With ABB Access, you can unlock all aspects of your drives, motors or PLCs, from one central location: the palm of your hand.

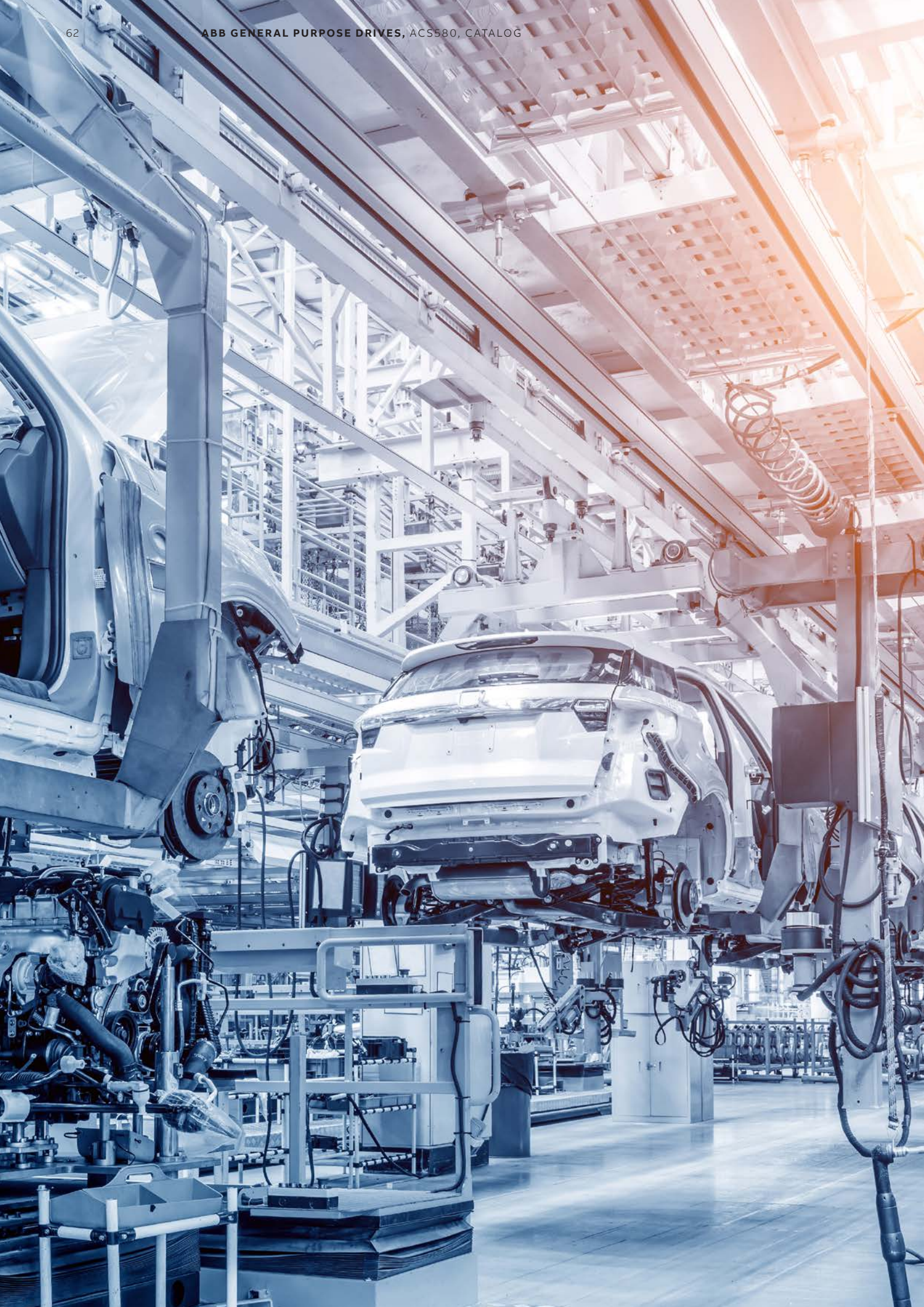

Simply scan the QR code on the ABB product to get started

ABB Access, helps you easily find up-to-date product online data. It also provides easy access to documentation and manuals. If you happen to experience issues with your ABB product, this can be fastly and easily reported online to reach expert support from ABB.



ABB Ability™ Mobile Connect for drives

Easy access to remote support

ABB Ability™ Mobile Connect for drives is a platform for remote drive support consisting of the Mobile Connect web portal and the Drivetune mobile app.

The platform allows ABB service partners to provide remote commissioning and troubleshooting support for personnel on-site without any complex connectivity infrastructure. Chats, sharing images and backups, viewing parameters online and sending support packages

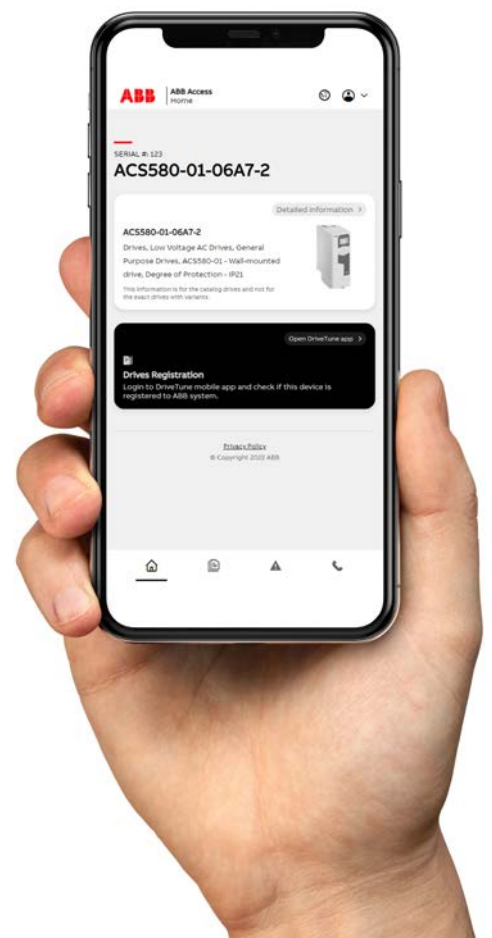
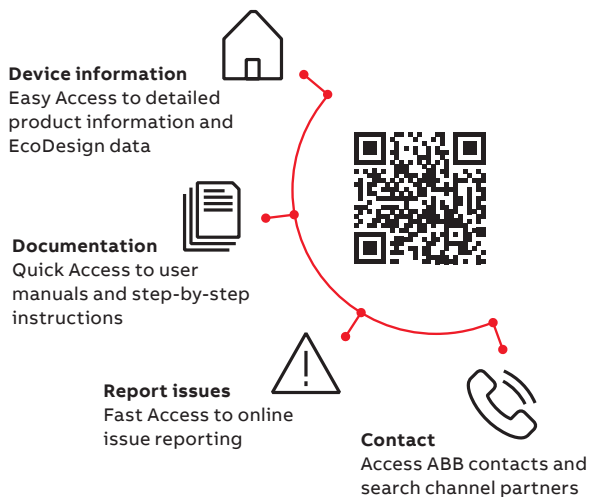
are all possible, making your technical support process quick and efficient.

All that is needed is the Bluetooth control panel and a mobile device.

The platform is available for ABB partners and OEMs under a renewable subscription-based agreement.

[ABB Ability™ Mobile Connect for drives support portal](#)

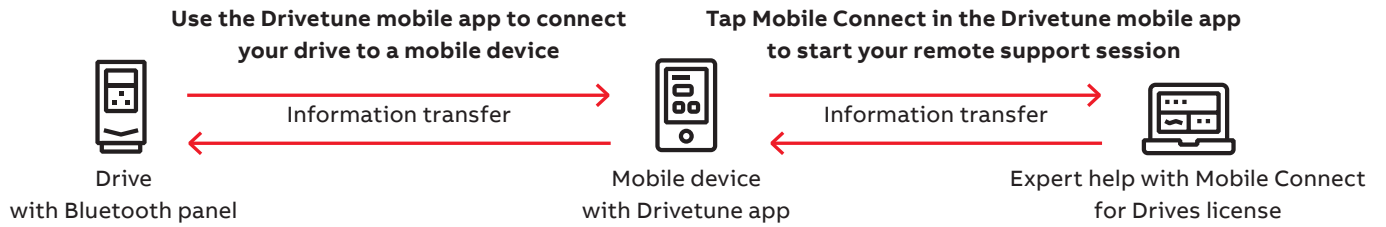

Drivetune mobile app for managing drives via an intuitive interface

Drivetune mobile app is a powerful tool for performing basic drive startup and troubleshooting tasks. It is possible to connect with drives and access data available in the Internet at the same time. The wireless Bluetooth

connectivity means that users won't need to enter hazardous or difficult-to-reach work areas to access information necessary to help them commission and tune the drive.



- **Startup, commission and tune your drive and application with full parameter access**
- **Optimize performance via drive troubleshooting features**
- **Create and share backups and support packages**
- **Keep track of drives installed base**

Download Drivetune mobile app



ABB SmartGuide – ACS580

Being one of the handiest ways to get short and clear visual instructions on drive installation, startup, and operation.

Mobile-friendly digital user guides provide simple and animated step-by-step instructions to assist with wall mounting of drives, electrical installation and drive programming. The content is frequently updated and further developed, making it your comprehensive source of instructions and help.

Scan the QR code and test it yourself!

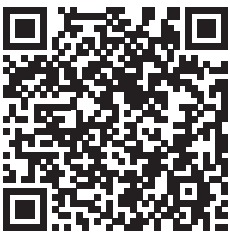
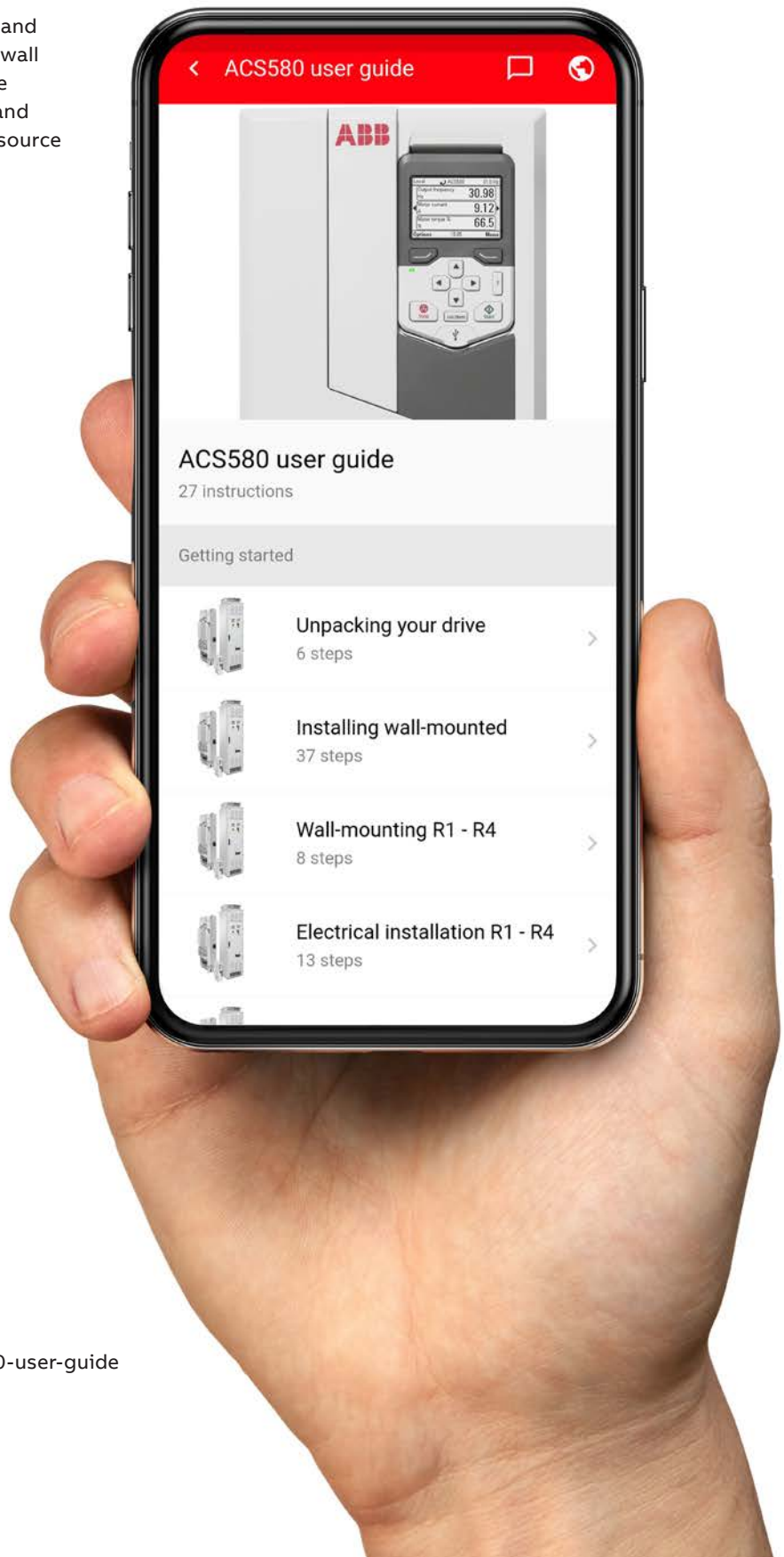

<https://drives-abb.swipeguide.com/guide/acs580-user-guide>
<https://drives-abb.swipeguide.com/>

Our service expertise, your advantage

ABB Motion Services helps customers around the globe by maximizing uptime, extending product life cycle, and enhancing the performance and energy efficiency of electrical motion solutions. We enable innovation and success through digitalization by securely connecting and monitoring our customers' motors and drives, increasing operational uptime, and improving efficiency. We make the difference for our customers and partners every day by keeping their operations running profitably, safely and reliably.

With a service offering tailored to your needs, ABB Motion Services maximizes the uptime and extends the life cycle of your electrical motion solutions, while optimizing their performance and maximizing your energy efficiency gains throughout the entire lifetime of your applications. We help to keep your applications turning profitably, safely and reliably.

Digitalization enables new smart and secured ways to prevent unexpected downtime while optimizing the operation and maintenance of your assets. We securely connect and monitor your motors, drives or your entire powertrain via our easy-to-use cloud service solutions. Connecting your applications also gives you access to our in-depth service domain expertise.

We quickly respond to your service needs. Together with our partners, local field service experts, and service workshop networks, we provide and install original spare parts to help resolve any issues and minimize the impact of unexpected disruptions.

Our tailored to your needs service offerings and digital solutions will enable you to unlock new possibilities. Not only are we your premier supplier of motion equipment, we are your trusted partner and advisor offering support throughout the entire life cycle of your assets. We ensure your operations run profitably, safely and reliably and continue to drive real world results, now and in the future. Our service teams work with you, delivering the expertise needed to keep your world turning while saving energy every day.



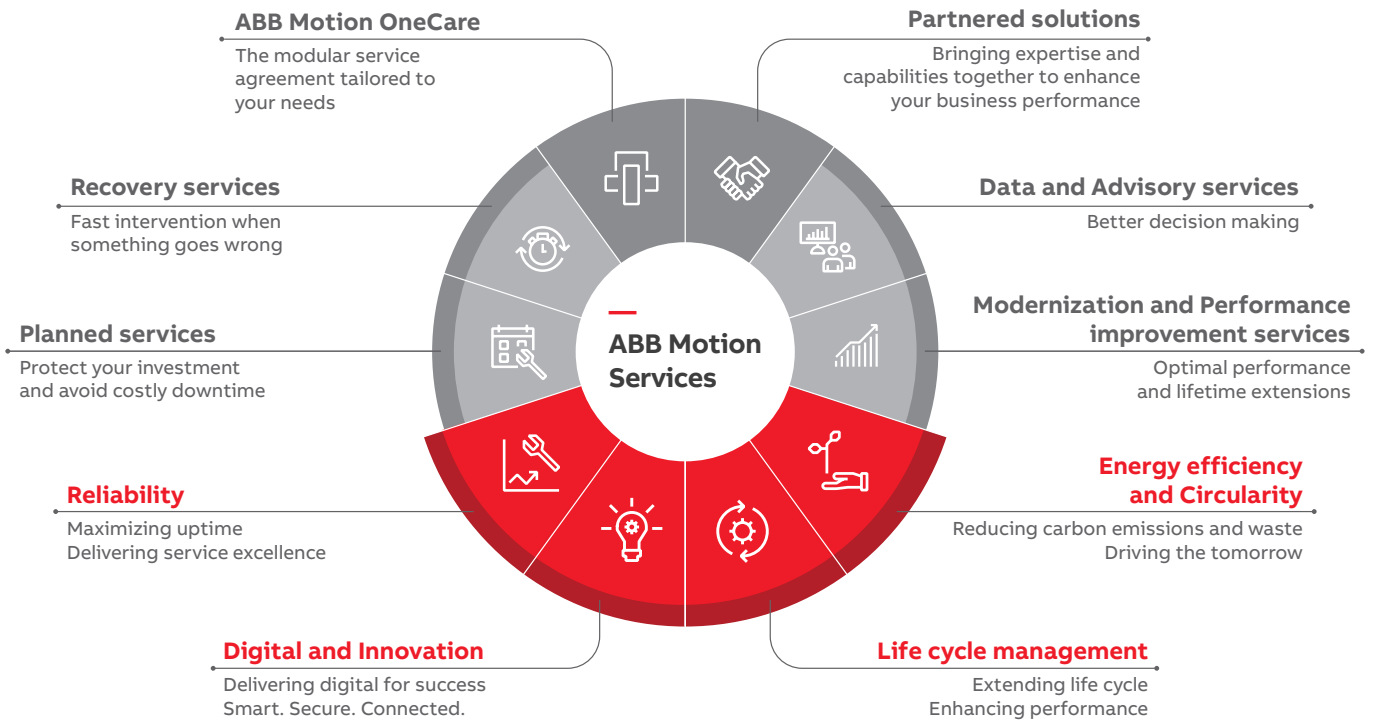

OUR EXPERTISE
YOUR ADVANTAGE



ABB Drives Life Cycle Management

A life time of peak performance

You're in control of every life cycle phase of your drives. At the heart of drive services is a four-phase product life cycle management model. This model defines the services recommended and available throughout drives lifespan.

Now it's easy for you to see the exact service and maintenance available for your drives.

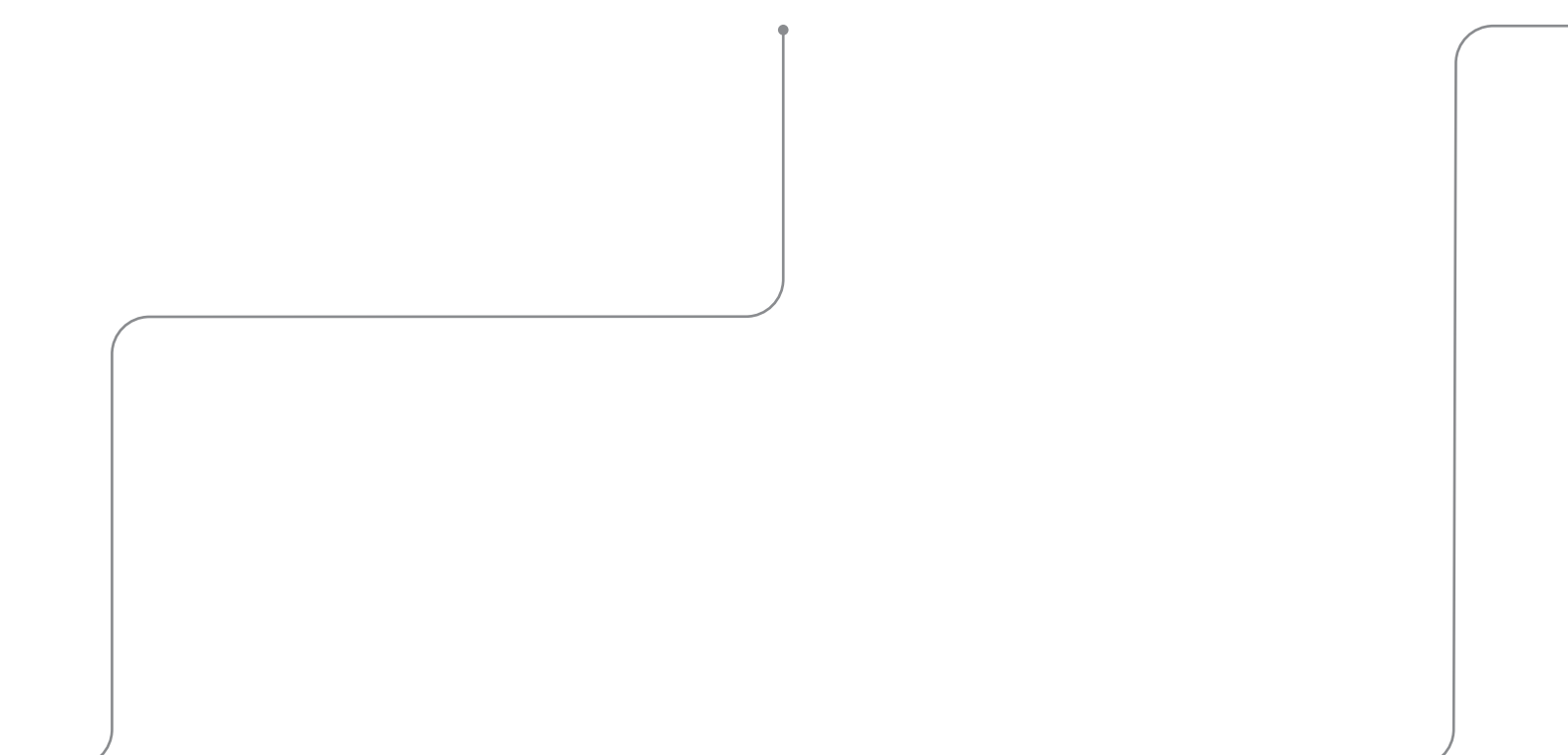
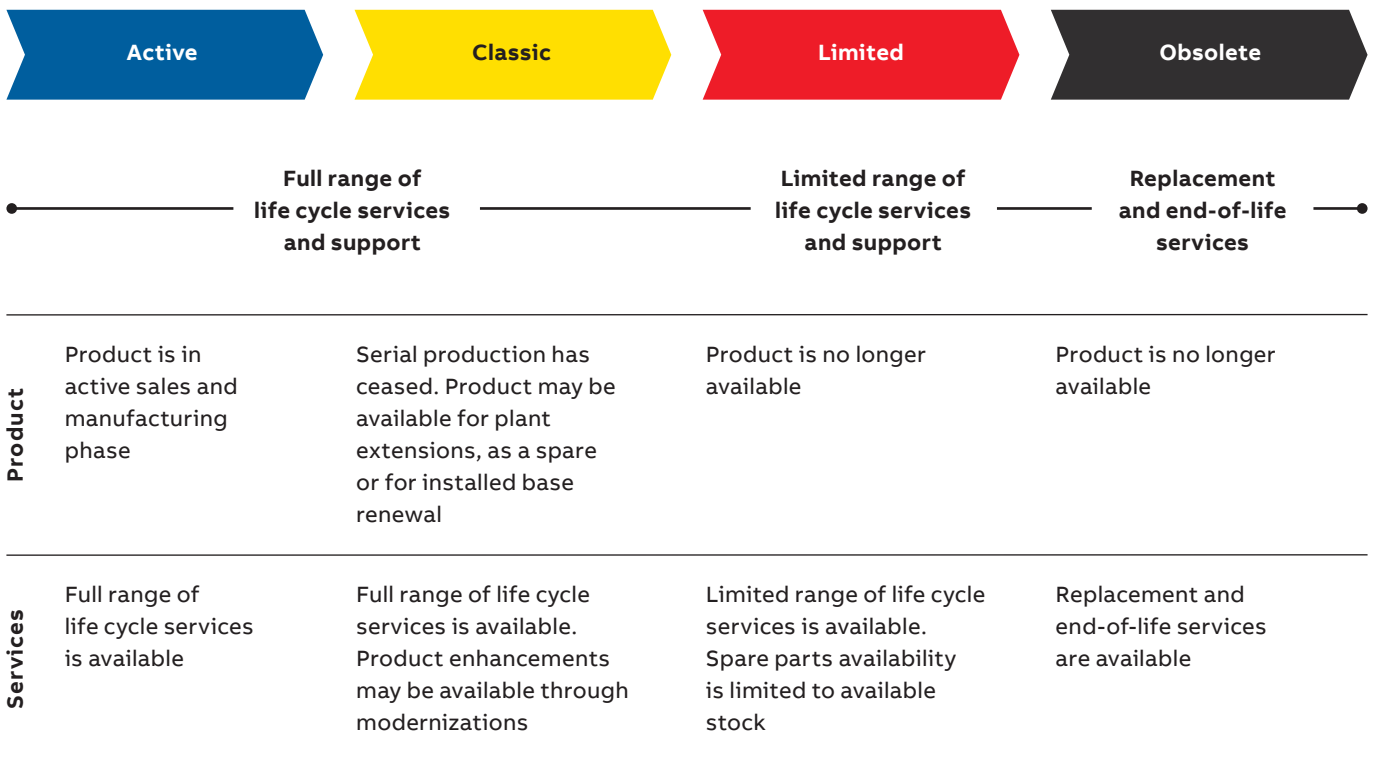

Keeping you informed throughout the life cycle

We notify you every step of the way using life cycle status statements and announcements.

Your benefit is clear information about your drives' status and precise services available. It helps you plan the preferred service actions ahead of time and make sure that continuous support is always available.

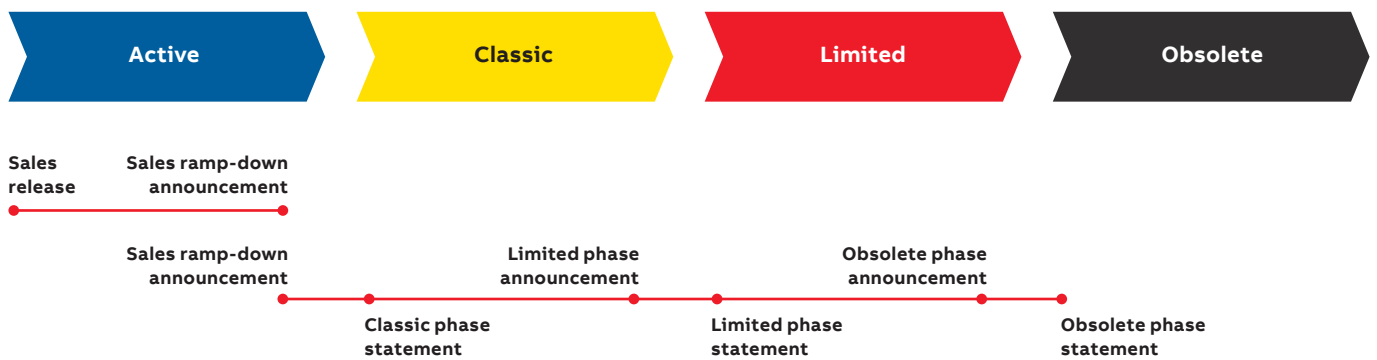

Sales release

Details about product portfolio and release schedule.

Sales ramp down announcement

Last time buy and last deliveries dates, informed well in advance.

Life cycle phase change announcement

Early information about the upcoming life cycle phase change and affects on the service availability. Informed well in advance, minimum six months prior to the change.

Life cycle phase statement

Information about the current life cycle status, product and services availability and recommended actions. Plan for the next life cycle phase transition.

Ordering information

How do I build an ordering code?

ACS580-01

The type designation tells you the specifications and configuration of the drive.

The table shows the primary drive variants.

Sample type code: ACS580-01-12A7-4+XXXX

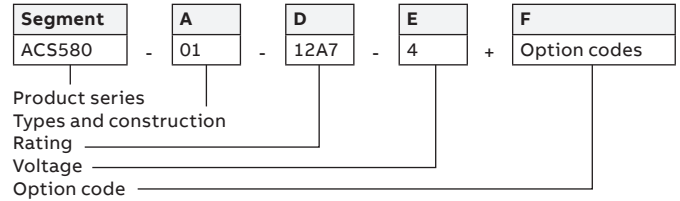

Basic codes

Segment	Option	Description
A	Construction	01 = When no options are selected: Wall mounted, IP21 (UL Type 1), assistant control panel with a USB port, choke, EMC C2 filter (internal EMC filter), Safe Torque Off, braking chopper in frames R1, R2, R3, coated boards, cable lead through entry from the bottom, cable box or the conduit plate with cable entries, quick installation and start-up guide multilingual)
D	Current rating	Refer to the rating table
E	Voltage rating	4 = 400/480 V (380...480 V) 2 = 230 V (200...240 V)

Option codes

Segment	Option	Code	Description
F	Control panel and panel options	+J400	ACS-AP-S Assistant control panel (as standard)
		+OJ400	Removes control panel
		+J404	ACS-BP-S Basic control panel
		+J424	CDUM-01 Blank control panel cover (no control panel)
		+J425	ACS-AP-I Assistant control panel
	I/O (one slot available for I/O options)	+J429	ACS-AP-W Assistant control panel with a Bluetooth interface
		+L500	CBAI-01 Bipolar analog I/O adapter module
		+L501	CMOD-01 External 24 V AC/DC and digital I/O extension (2×RO and 1×DO)
		+L512	CHDI-01 115/230 V Digital input extension (6×DI and 2×RO)
		+L523	CMOD-02 External 24 V AC/DC and isolated PTC interface
		+L525	CAIO-01 analogue signal extension (3 x AI and 2 x AO)
		+L537	CPTC-02 ATEX-certified PTC interface, Ex II (2) GD and external 24 V. Requires also option +Q971.
	Safety	+Q971	ATEX-certified Safe Disconnection Function, Ex II (2) GD. Sold only with option +L537.
	Fieldbus	+K451	DeviceNet™ (FDNA-01)
		+K454	PROFIBUS® DP (FPBA-01)
		+K457	CANopen® (FCAN-01)
		+K462	ControlNet™ (FCNA-01)
+K469		EtherCAT® (FECA-01)	
+K470		Ethernet POWERLINK (FEPL-01)	
+K475		2-port Ethernet (EtherNet/IP™, Modbus®/TCP, PROFINET®)	
+K490		EtherNet/IP™ (FEIP-21)	
+K491		Modbus®/TCP (FMBT-21)	
+K492		PROFINET® IO (FPNO-21)	
Embedded fieldbus	+CEIA-01	Embedded Modbus RTU adapter	
	+EIA-485	(as standard)	
IP enclosure	+B056	IP55 (UL type 12). Factory option, retrofit not possible.	
Construction	+C135	Flange mounting kit. (Only available for 400V IP21 drives)	
	+H358	Cable conduit plate, blank	
	+P944	Drive without cable entry box. Version for cabinet mounting (R5-R9).	
	+F278	Main switch disconnecter (R1-R5)	
	+E223	EMC filter, category C1 for earthed network (R1-R5)	
	+F316	Main switch and EMC filter, category C1 for earthed network (R1-R5)	
	Complementary options	+C219	Overall drive (R1-R5 frames) to comply with class C4 (IEC60721-3-3:2019/ISO9223) or class 3C3 (IEC60721-3-3:2002), ammonia only
+P931		Extended warranty up to 36 months	
+P932		Extended warranty up to 60 months	
+P952		European Union Country of origin	
Software		+N2000	Standard language package
	+N2901	Europe language package	
	+N2902	Asia language package	
	+N8057	Food and beverage software package	

ACS580-04

The type designation tells you the specifications and configuration of the drive.

The table shows the primary drive variants.

Sample type code: ACS580-04-505A-4+XXXX

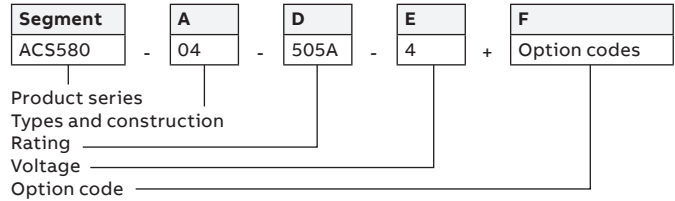

Basic codes

Segment	Option	Description
A	Construction	04 = Drive with coated circuit boards, integrated control unit (inside drive module), control panel door mounting kit, embedded Modbus RTU adapter, EIA-485 (standard), assistant control panel with USB-port, quick guides with default set of languages, web links to basic PC tool and manuals in quick guide
D	Current rating	Refer to the rating table
E	Voltage rating	4 = 380...480 V

Option codes

Segment	Option	Code	Description	
F	Control panel and panel options	+J400	Assistant control panel (standard) / ACS-AP-S (+J400 is included in the standard delivery)	
		+OJ400	No control panel	
		+J425	Assistant control panel /ACS-AP-I (+J425 and +J404 replaces +J400 / ACS-AP-S)	
		+J404	Basic control panel / ACS-BP-S (+J425 and +J404 replaces +J400 / ACS-AP-S)	
			+J429	Assistant control panel with bluetooth interface / ACS-AP-W
	I/O (one slot available for I/O options) (L501, L523 and L512 available as retrofit options)		+L500	CBAI-01 Bipolar analog I/O adapter module
			+L501	External 24 V DC/AC and Digital I/O extension (2xRO and 1xDO) / CMOD-01
			+L512	115/230V Digital input (6xDI and 2xRO) / CHDI-01
			+L523	External 24 V and isolated PTC interface / CMOD-02
			+L525	CAIO-01 analogue signal extension (3 x AI and 2 x AO)
			+L537	ATEX-certified PTC interface, Ex II (2) GD and external 24 V / CPTC-02. Requires also +Q971 option.
		Safety	+Q971	ATEX-certified Safe Disconnection Function, Ex II (2) GD / CPTC-02 (+Q971 option sold only together with +L537 option)
	Fieldbus (One fieldbus adapter supported. Fieldbus adapters available as loose options for retrofit.)	Fieldbus	+K451	DeviceNet™ (FDNA-01)
		+K454	PROFIBUS® DP (FPBA-01)	
		+K457	CANopen® (FCAN-01)	
		+K462	ControlNet™ (FCNA-01)	
		+K469	EtherCAT® (FECA-01)	
		+K470	Ethernet POWERLINK (FEPL-01)	
		+K475	2-port Ethernet (EtherNet/IP™, Modbus®/TCP, PROFINET®)	
		+K490	EtherNet/IP™ (FEIP-21)	
	+K491	Modbus®/TCP (FMBT-21)		
	+K492	PROFINET® IO (FPNO-21)		
IP enclosure		+B051	IP20 Finger safe	
Construction		+J410	Control panel door mounting kit (+J410 Includes DPMP-03)	
		+H370	Full-size input terminals	
		+P906	Remote control board	
		+OH371	No full size output terminals	
		+OH534	No pedestal	
		+OP919	No cabinet installation ramp	
Filters		+E210	EMC/RFI-filter, C3, 2 nd Environment, Unrestricted (Earthed & Unearthed Networks)	
		+E208	Common mode filter	
Resistor braking		+D150	Brake chopper	
Complementary options		+P931	Extended warranty up to 36 months	
		+P932	Extended warranty up to 60 months	
		+P952	European Union Country of origin	
Software		+N8057	Food and beverage software package	

Ordering information

How do I build an ordering code?

ACS580-07

The type designation tells you the specifications and configuration of the drive.

The table shows the primary drive variants.

Sample type code: ACS580-07-145A-4+XXXX

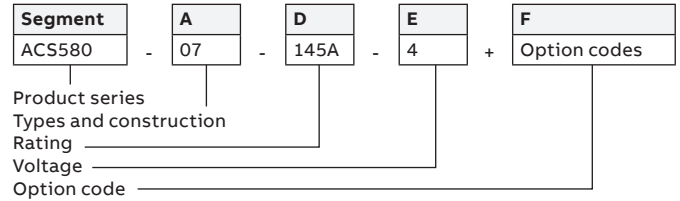

Basic codes

Segment	Option	Description
A	Construction	07 = Cabinet-built, IP21, Main switch and aR fuses, Assistant control panel (ACS-AP-S), EMC filter C2 (R6-R9)/C3 (R10-R11), Common mode filter (R10-R11), ACS580 standard control program, Safe Torque Off, Boards with coating, Bottom entry and exit of cables, Cable lead through entry, One set of default electric documents in USB stick
D	Current rating	Refer to the rating table
E	Voltage rating	4 = 380...480 V

Option codes

Segment	Option	Code	Description
F	Control panel and panel options	+J429	ACS-AP-W Assistant control panel with Bluetooth interface
	I/O (one slot available for I/O options)	+L500	CBAI-01 Bipolar analog I/O adapter module
		+L501	External 24 V DC/AC and Digital I/O extension (2xRO and 1xDO)
		+L504	Additional I/O-Terminal Block
		+L512	115/230V Digital input (6xDI and 2xRO)
		+L523	External 24 V and isolated PTC interface
		+L525	CAIO-01 analogue signal extension (3 x AI and 2 x AO)
		+L537	ATEX-certified thermistor protection module, Ex II (2) GD (requires ATEX-certified Safe Disconnection Function, Ex II (2) GD, add +Q971 to code)
	Options for cabinet	+L506 *)	Pt100 relay 1 pc (non Ex compatible)
		+2L506 *)	Pt100 relay 2 psc (non Ex compatible)
		+3L506 *)	t100 relay 3 pcs (non Ex compatible)
		+5L506 *)	Pt100 relay 5 pcs (non Ex compatible)
		+G307 *)	Terminal for external AC control voltage
		+H537 *)	Cable lead through entry (European)
	Safety	+Q971	ATEX-certified Safe Disconnection Function, Ex II (2) GD (+Q971 option sold only together with +L537 option. Not available with +Q951)
		+Q951	Safety option of emergency stop where Main breaker is opened during emergency
		+Q963	Safety option of emergency stop where main breaker is not opened during emergency
	Fieldbus (One fieldbus adapter supported. Note: Embedded fieldbus interface can't be used at the same time with fieldbus adapter. Fieldbus adapters available as loose options for retrofit.)	+K451	DeviceNet™ (FDNA-01)
		+K454	PROFIBUS® DP (FPBA-01)
		+K457	CANopen® (FCAN-01)
+K462		ControlNet™ (FCNA-01)	
+K469		EtherCAT® (FECA-01)	
+K470		Ethernet POWERLINK (FEPL-01)	
+K475		2-port Ethernet (EtherNet/IP™, Modbus®/TCP, PROFINET®)	
+K490		EtherNet/IP™ (FEIP-21)	
+K491	Modbus®/TCP (FMBT-21)		
+K492	PROFINET® IO (FPNO-21)		
ABB Ability™ Condon Monitoring for drives	+K496	NETA-21 Wired remote monitoring system	
	+K497	Connectivity for wireless remote monitoring (Not released, requires +K496)	
IP enclose	+B054	IP42 enclosure class (Type 1 in case of UL certification)	
	+B055	IP54 enclosure class (Type 12 in case of UL certification)	
Construction	+C129	Cabinet drive is UL listed	
	+C180	Seismic design	
Filters	+E205	Du/dt filter	
	+E208	Common mode filter (as a default for R10-R11)	
	+F250	Line contactor	
	+F289	Molded case circuit breaker (UL listed, requires C129 option)	

Option codes				
Segment	Option	Code	Description	
F	Cabling	+H351	Top entry (additional channel for frames R6-R9, +125 mm the drive cabinet width) Top entry through roof (frames R10-R11)	
		+H353	Top exit (additional channel for frames R6-R9, +125mm the drive cabinet width) Top exit (frames R10-R11) – additional 150 mm channel	
		+H358	Cable conduit entry (Default in US, anywhere else specify in order)	
		+C164	Plinth 100 mm (separate in package)	
		+C179	Plinth 200 mm (separate in package)	
		Cabinet options	+C128	Cooling air intake through bottom of cabinet
			+C130	Channeled air outlet
			+C196	Empty cabinet 400 mm on right side (not available with +H351 and/or +H353 for frames R6-R9)
			+C197	Empty cabinet 600 mm on right side (not available with +H351 and/or +H353 for frames R6-R9)
			+C198	Empty cabinet 800 mm on right side (not available with +H351 and/or +H353 for frames R6-R9)
	+C199		Empty cabinet 400 mm on left side (not available with +H351 and/or +H353 for frames R10-R11)	
	+C200		Empty cabinet 600 mm on left side (not available with +H351 and/or +H353 for frames R10-R11)	
	+C201		Empty cabinet 800 mm on left side (not available with +H351 and/or +H353 for frames R10-R11)	
	+G300		Cabinet heater (External supply)	
	+G313		Output for motor heater	
	+G327		Ready Pilot light, white	
	+G307		Terminals for external control voltage	
	+G328		Run Pilot light, green	
	+G329	Fault Pilot light, red		
	Starter for auxiliary motor fan	+M600	1...1.6 A; 1PC-s, dimensioned by fan size, Includes protective devices	
		+M601	1.6...2.5 A; 1PC-s, dimensioned by fan size, Includes protective devices	
		+M602	2.5...4 A; 1PC-s, dimensioned by fan size, Includes protective devices	
		+M603	4...6.3 A; 1PC-s, dimensioned by fan size, Includes protective devices	
		+M604	6.3...10 A; 1PC-s, dimensioned by fan size, Includes protective devices	
		+M605	10...16 A; 1PC-s, dimensioned by fan size, Includes protective devices	
	Complementary options	+P931	Extended warranty up to 36 months	
		+P932	Extended warranty up to 60 months	
	Specialities	+P912	Seaworthy Packing (R10, R11: High Cube (HC) container required for reshipping)	
		+P929	Container Packing (R10, R11: High Cube (HC) container required for reshipping)	
	Software	+N2000	Standard language package	
		+N2901	Europe language package	
		+N2902	Asia language package	
		+N8057	Food and beverage software package	

*) Notes:

- Options +L506, +2L506, +3L506, +5L506 are required to have built-in relays into the cabinet.
This relay can acquire the Pt100 signal from the motors and generate a safe voltage that can be applied to the control board where the customer can generate an external event; only one of this option can be selected at the time.
- Option +G307 is making available terminals for external AC control voltage.
- European cable lead entry is included in the standard configuration.
Option +H357 can be selected only when option +C129 has been pre-selected; +H357 is not compatible with option with +H358.
- Only one "Starters for auxiliary fan" option can be selected at the time.

Additional information

We reserve the right to make technical changes or modify the contents of this document without prior notice. With regard to purchase orders, the agreed particulars shall prevail. ABB does not accept any responsibility whatsoever for potential errors or possible lack of information in this document.

We reserve all rights in this document and in the subject matter and illustrations contained therein. Any reproduction, disclosure to third parties or utilization of its contents – in whole or in parts – is forbidden without prior written consent of ABB.



—
For more information, please contact
your local ABB representative or visit

- new.abb.com/drives/ACS580
- new.abb.com/drives/general-purpose
- new.abb.com/drives
- new.abb.com/drives/drivespartners
- new.abb.com/motors-generators

ACS580 technical animation video



Video playlist:
ACS580 how-to videos

